



March 28, 2012

Tecumseh Compressor Company Indoor Condensing Units

Model: AKA9463ZXAXC

BoM: 2B788-1

R-404A

3/4 HP

AIR COOLED

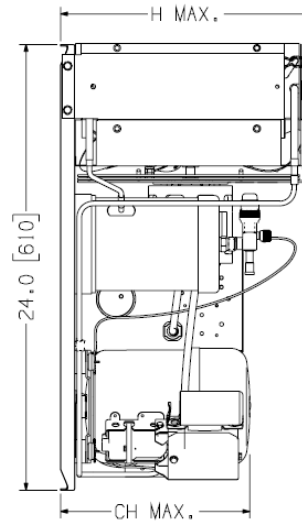
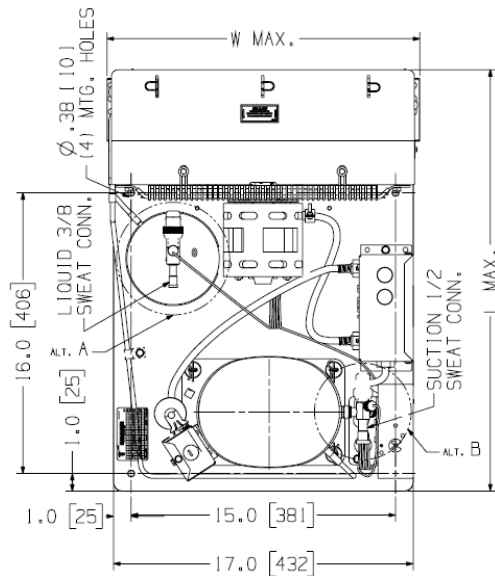

Model	Dimensions, inches				Line Connection*		Pump down	Air	Oil Ch	Gr. Wt.
	L	W	H	CH	Suction	Liquid	90°F 90%	SCFM	Oz.	Lbs.
AKA9463ZXAXC	24.3	18.0	14.0	10.2	1/2" S	3/8" S	6.0 lbs	600	17.0	84

* F = Flare, S = Solder, RF or RS = Rotolock with Flare or Solder Connections, C = Compression Fitting

Evaporator T,		Ambient Temperatures											
		90°F				100°F				110°F			
°F	PSIG	BTUH	Watts	Head	Cond T	BTUH	Watts	Head	Cond T	BTUH	Watts	Head	Cond T
-10	23.9	3190	1020	255	105	2650	995	285	113	2170	950	315	121
-5	28.2	3700	1090	260	107	3120	1035	295	116	2580	1035	325	123
0	32.8	4200	1160	270	109	3550	1150	300	117	2980	1120	335	125
5	37.9	4720	1230	280	112	4020	1225	310	119	3380	1210	345	127
10	43.3	5230	1300	290	114	4480	1300	320	122	3780	1300	355	130
15	49.2	5750	1380	295	116	4930	1390	330	124	4180	1390	365	132
20	55.5	6280	1450	305	118	5380	1470	340	126	4600	1480	375	134
25	62.2	6900	1530	315	121	5980	1550	350	129	5100	1575	385	136
30	69.5	7650	1610	325	123	6570	1640	365	132	5600	1670	395	138
35	77.2	8200	1690	340	126	7150	1730	375	134	6150	1770	405	140
40	85.5	8900	1780	350	129	7700	1830	385	136	---	---	---	---
45	94.3	9600	1880	360	131	8300	1930	400	139	---	---	---	---

60 Hz Performance

Return gas temp. 40°F, 5°F sub cooling

