

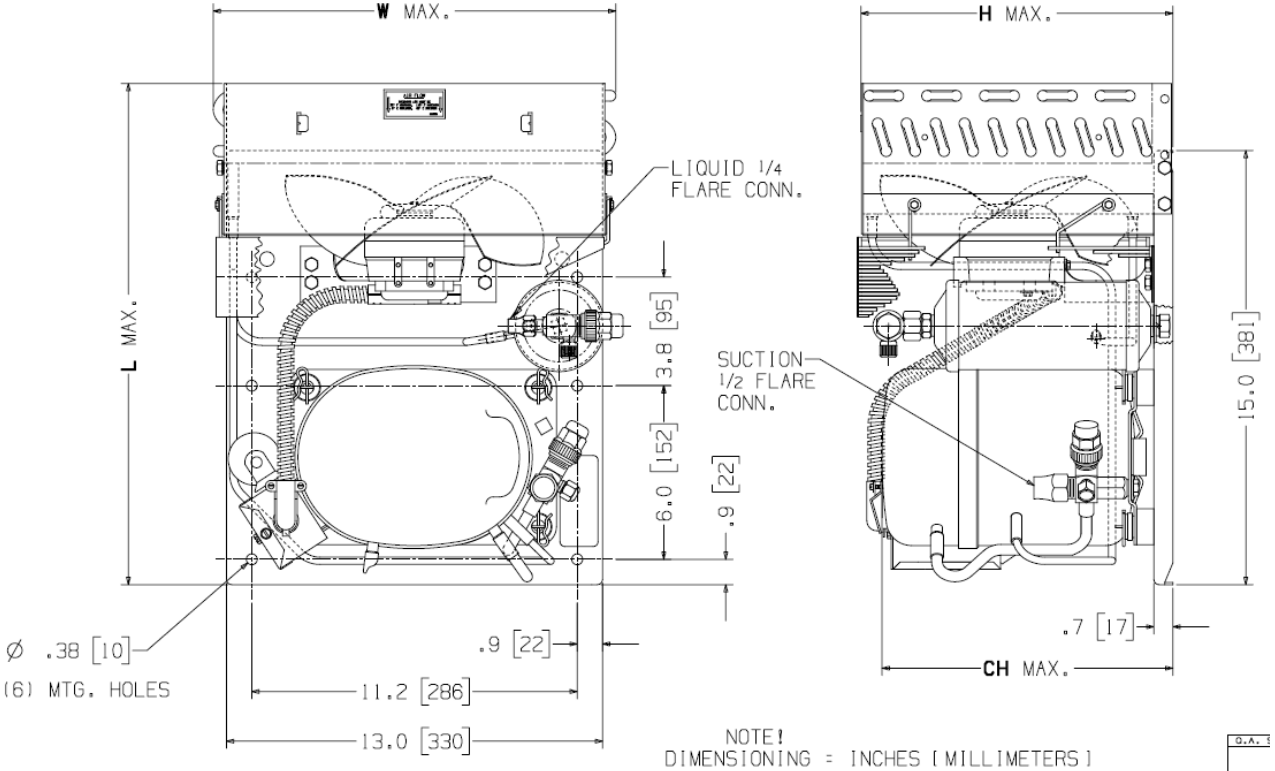

Indoor Condensing Unit Technical Data Sheet

Model: AKA4460YXAXC BoM: 2C238-1 R-134a / R-513A 1/2 HP



Model	Dimensions, inches				Line Connection*		Pumpdown	Air	Oil Ch	Gr. Wt.
	L	W	H	CH	Suction	Liquid	90 °F 90%	SCFM	Oz.	Lbs.
AKA4460YXAXC	17.4	14.0	10.9	10.6	1/2" F	1/4" F	3.3 lbs.	350	17	68

* F = Flare, S = Solder, RF or RS = Rotolock with Flare or Solder Connections, C = Compression Fitting
 Factory charge: 20 PSIG Nitrogen – **MUST BE EVACUATED**

Evaporator T,		R-134a Performance											
		Ambient Temperatures											
		80°F			90°F			100°F			110°F		
°F	PSIG	BTUH	Watts	Cond T	BTUH	Watts	Cond T	BTUH	Watts	Cond T	BTUH	Watts	Cond T
20	18.4	3654	634	109	3353	641	116	3052	648	124	2751	655	132
25	22.1	4088	689	112	3745	707	120	3401	725	128	3058	743	136
30	26.1	4536	735	116	4150	764	124	3765	792	131	3379	821	139
35	30.4	4998	771	120	4570	810	128	4142	850	135	3714	889	143
40	35.1	5475	797	124	5004	847	131	4534	897	139	---	---	---
45	40.1	5965	814	128	5452	874	135	---	---	---	---	---	---
50	45.5	6469	820	132	5914	891	139	---	---	---	---	---	---
55	51.3	6987	817	135	6389	899	143	---	---	---	---	---	---

60 Hz Performance
 Return gas temp. 65°F, 5°F sub cooling

Evaporator T,		R-513A Performance											
		80°F			90°F			100°F			110°F		
°F	PSIG	BTUH	Watts	Cond T	BTUH	Watts	Cond T	BTUH	Watts	Cond T	BTUH	Watts	Cond T
20	22.4	3785	690	108	3474	698	115	3162	706	123	2850	713	130
25	26.4	4235	750	111	3880	770	119	3523	789	127	3168	809	134
30	30.6	4699	800	115	4299	832	123	3900	862	129	3500	894	137
35	35.2	5178	840	119	4734	882	127	4291	926	133	3847	968	141
40	40.1	5672	868	123	5184	922	129	4697	977	137	---	---	---
45	45.4	6179	886	127	5648	952	133	---	---	---	---	---	---
50	51.1	6702	893	130	6127	970	137	---	---	---	---	---	---
55	57.1	7238	890	133	6619	979	141	---	---	---	---	---	---

60 Hz Performance

Return gas temp. 65°F, 5°F sub cooling

COMP

Specifications/ Parts:

Unit Model	AKA4460YXAXC
Unit Bill of Material	2C238-1
Refrigeration Range	20 F to 55° F
Design Pressure Low	150
Design Pressure High	450
Nominal Volts-Hz-Ph	115/60/1
Voltage Range	103 to 127
Min. Circuit Ampacity	12.46
Max. Fuse Size (amps)	20
Compressor Model	AKA4460YXA
Comp. Bill of Material	AK168AT-032-J7
Compressor RLA/LRA	9.5/48
Overload	8300MRAG17
Relay	8200EMBJ97
Run Capacitor	N/A
Start Capacitor	85PS165C96

Fan Motor	810M009C09
Fan Motor RLA	0.53
Fan Blade	51564-1
Fan Shroud	70766-1
Fan Guard	70959
Condenser	50840-2
Receiver Tank	51080-1
Liquid Valve	31584-1
Suction Valve	56571-2
Power Cord	N/A
HP Switch	N/A
Unit Drawing	DGU1909-2
Wiring Diagram	90701
Replacement Kit: Relay	LP145
Replacement Kit: O/L	K90-23
Replacement Kit: St. Cap	K146-25

Electrical Diagram

