

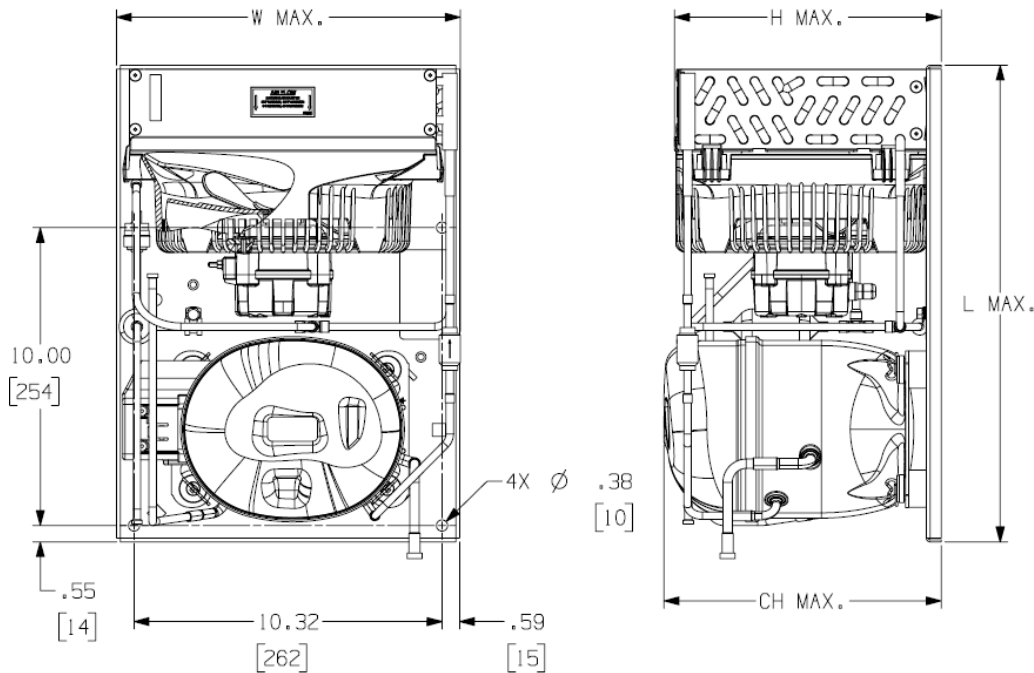

Indoor Condensing Unit Technical Data Sheet

Model: AEX424U-FZ3BCK BoM: 2F200-29S R-290 1/2 HP



Model	Dimensions, inches				Line Connection*		Pumpdown	Air	Oil Ch	Gr. Wt.
	L	W	H	CH	Suction	Liquid	90 °F 90%	CFM	Oz.	Lbs.
AEX424U-FZ3BCK	16.0	11.6	8.9	9.3	5/16" S	1/4" S	N/A	230	13.1	40
* F = Flare, S = Solder, RF or RS = Rotolock with Flare or Solder Connections, C = Compression Fitting Factory charge: 20 PSIG Nitrogen – MUST BE EVACUATED										

Evaporator		R-290 Performance											
		Ambient Temperatures											
		80°F			90°F			100°F			110°F		
°F	PSIG	BTU/H	Watts	Cond T	BTU/H	Watts	Cond T	BTU/H	Watts	Cond T	BTU/H	Watts	Cond T
-30	5.7	1483	350	96	1379	356	105	1274	361	114	1170	367	123
-25	8.1	1649	366	98	1530	373	107	1410	379	116	1291	386	125
-20	10.7	1822	382	100	1688	390	109	1553	399	118	1418	407	127
-15	13.6	2001	400	102	1852	409	111	1702	419	120	1552	428	129
-10	16.7	2187	419	105	2022	430	113	1857	440	122	1693	451	131
-5	20.1	2379	439	107	2199	451	116	2019	463	125	1839	475	133
0	23.7	2578	460	110	2383	473	118	2188	487	127	1993	501	135
5	27.6	2783	482	112	2572	497	121	2362	512	129	2152	527	138
10	31.8	2994	506	115	2769	522	124	2543	539	132	2318	555	140
15	36.3	3212	531	118	2971	548	126	2731	566	135	---	---	---
20	41.1	3436	557	121	3180	576	129	2925	595	138	---	---	---

Performance @ 50Hz, Return Gas 40°F for 20°F and Below Evaporator and 65°F above 20°F Evaporator, Sub cooling 5°F

Specifications/ Parts:

Unit Model	AEX424U-FZ3BCK
Unit Bill of Material	2F200-29S
Refrigeration Range	-30° F to 20° F
Design Pressure Low	130
Design Pressure High	450
Nominal Volts-Hz-Ph	220-240/50/1
Voltage Range	198 to 253
Min. Circuit Ampacity	2.4
Max. Fuse Size (amps)	15
Compressor Model	AEX424U-FZ3B
Comp. Bill of Material	AE1902E-208-J7
Compressor RLA/LRA	1.84/17.5
Overload	830-10512
Relay	820-10398
Run Capacitor	85PR440F24
Start Capacitor	85PS330D14

Fan Motor	810-10141
Fan Motor RLA	.14
Fan Blade	51593
Fan Shroud/Guard Combo	116-002P
Condenser	506-G434
Receiver Tank	N/A
Liquid Valve	N/A
Suction Valve	N/A
Power Cord	85294-1 (No Plug)
High Pressure Switch	841-10000
Unit Drawing	DGU1980-6
Wiring Diagram	91267-02
Replacement Kit: Relay	K71-103
Replacement Kit: O/L	K90-154
Replacement Kit: St. Cap	K146-41
Replacement Kit: Run Cap	K150-04

Electrical Diagram

