



*Tecumseh*

# Celseon® Air Cooled Condensing Unit

Model: AKA9442ZAAD\*

BoM: 2G212-\*\*

R-404a

1/2 HP

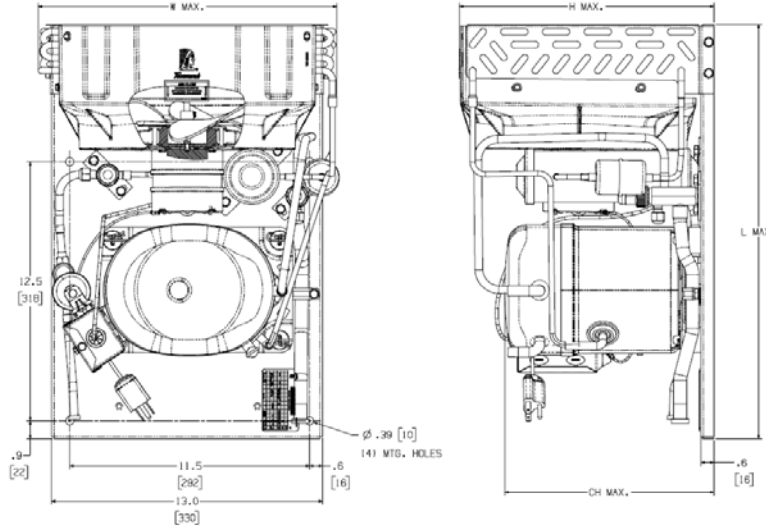

Model	Dimensions, inches				Line Connection*		Pumpdown	Air	Oil Ch	Gr. Wt.
	L	W	H	CH	Suction	Liquid	90 °F 90%	SCFM	Oz.	Lbs.
AKA9442ZAADA	20.0	14.3	12.1	10.1	3/8" S	1/4" S	N/A	230	17	53
AKA9442ZAADG					5/8" S	3/8" S	2.7 lbs			54
AKA9442ZAADH					5/8" S	3/8" S	N/A			53
AKA9442ZAADK					3/8" S	1/4" S	N/A			53
AKA9442ZAADC					5/8" S	3/8" S	2.7 lbs			54
AKA9442ZAADS					5/8" S	3/8" S	N/A			53
AKA9442ZAADJ					5/8" S	3/8" S	2.7 lbs			54
AKA9442ZAADP					5/8" S	3/8" S	2.7 lbs			54

\* F = Flare, S = Solder, RF or RS = Rotolock with Flare or Solder Connections, C = Compression Fitting

Factory charge: 20 PSIG Nitrogen – **MUST BE EVACUATED**

### Ambient Temperatures

Evaporator T,		Ambient Temperatures											
		80°F			90°F			100°F			110°F		
°F	PSIG	BTUH	Watts	Cond T	BTUH	Watts	Cond T	BTUH	Watts	Cond T	BTUH	Watts	Cond T
-10	23.7	2518	611	92	2033	585	100	1792	591	109	1433	531	117
-5	28.0	2904	659	94	2394	637	102	2101	638	111	1680	587	119
0	33.4	3355	621	98	2691	573	106	2077	526	114	1513	479	121
5	37.6	3859	676	100	3172	636	107	2532	597	115	1943	558	122
10	43.9	4383	731	102	3672	700	109	3007	668	117	2392	637	124
15	49.8	4914	787	104	4179	764	111	3491	740	119	2850	716	126
20	56.1	5439	844	107	4681	828	114	3969	812	122	3302	796	129
25	62.9	5942	901	111	5162	893	118	4425	885	125	3733	877	132
30	70.2	6404	958	115	5601	958	122	4840	958	129	4121	958	136
35	77.9	6803	1017	120	5978	1024	127	5192	1032	134	4444	1040	140
40	87.0	7114	1075	126	6264	1091	132	5450	1106	139	---	---	---
45	95.1	7304	1134	132	6425	1158	138	---	---	---	---	---	---

### 60 Hz Performance

Return gas temp 40°F below 20°F evaporator,  
and 65°F above 20° evap, 5°F sub cooling



## Electrical Diagram Page 3

