

1-1/4 to 2-4/5 HP Medium Temperature Platform (Tube Fin)

Project Name:	
Customer Name:	
Model Number:	
Refrigerant:	
Job Location:	
Date:	
AWEF:	

MEDIUM CHASSIS

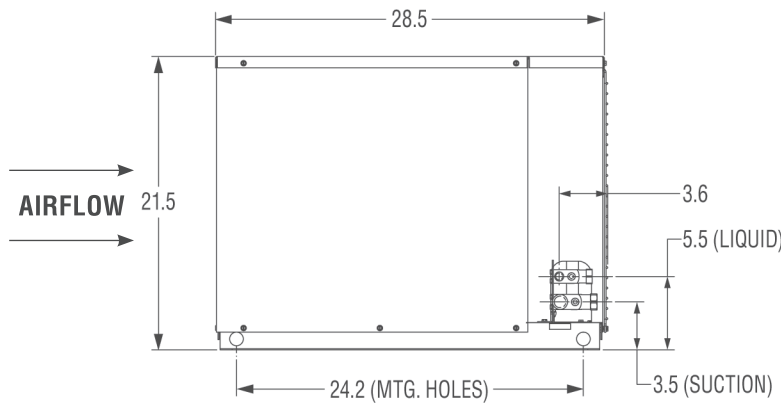
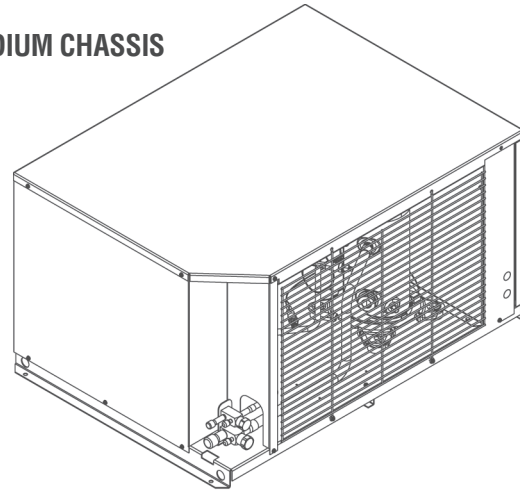

SIDE VIEW

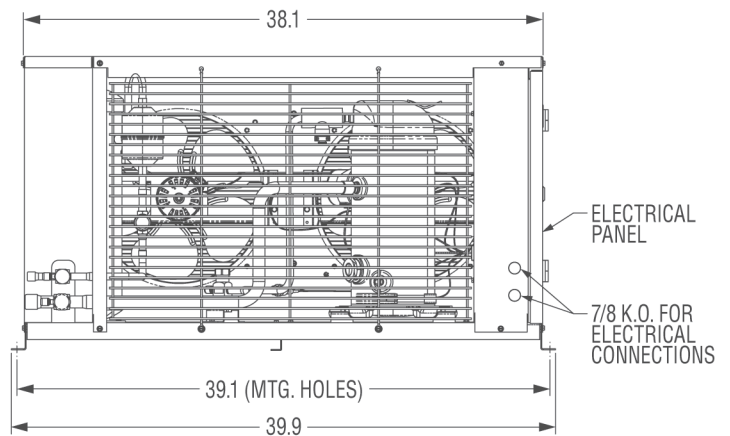

FRONT VIEW

Physical Data

ARGUS Series	Model Number	Compressor		Connections (inch)		Pump Down Capacity* (lbs) 90% @ 90°F Ambient / R-404A		Net Weight (lbs)
		Model Number	HP	Liquid	Suction	Standard	Oversized	
R-404A R-448A R-449A R-452A	AS*R9510ZNA***	AW9480ZXN	1-1/4	3/8" S	5/8" S	22.12	26.85	234
	AS*R9510ZFA***	AW9480ZXT	1-1/4	3/8" S	5/8" S	22.12	26.85	234
	AS*R9512ZNA***	AWA9512ZXN	1-1/2	3/8" S	5/8" S	22.12	26.85	234
	AS*R9512ZFA***	AWA9512ZXT	1-1/2	3/8" S	5/8" S	22.12	26.85	234
	AS*S9516ZNA***	VSC9515XNA	2	1/2" S	7/8" S	22.12	26.85	234
	AS*S9516ZFA***	VSC9516XMA	2	1/2" S	7/8" S	22.12	26.85	234
	AS*S9520ZNA***	VSC9519XNA	2-1/2	1/2" S	7/8" S	22.12	26.85	234
	AS*S9520ZFA***	VSC9519XMA	2-1/2	1/2" S	7/8" S	22.12	26.85	234
	AS*S9522ZNA***	VSC9521XNA	2-4/5	1/2" S	7/8" S	22.12	26.85	234
	AS*S9522ZFA***	VSC9521XMA	2-4/5	1/2" S	7/8" S	22.12	26.85	234

*Receiver + Coil Capacity

Electrical Data

Model Number	Power Supply	Compressor		Condensing Unit		Fan Motor (PSC)			Fan Motor (EC)		
	Volts/Hz/Ph	RLA	LRA	MCA*	MOPD	Qty	HP	FLA	Qty	HP	FLA
AS*R9510ZNA***	208-230/60/1	10.30	52	13.9	20	2	1/20	0.45	2	1/20	0.5
AS*R9510ZFA***	208-230/60/3	6.40	51	9.1	15	2	1/20	0.45	2	1/20	0.5
AS*R9512ZNA***	208-230/60/1	12.40	60	16.7	25	2	1/20	0.45	2	1/20	0.5
AS*R9512ZFA***	208-230/60/3	7.75	50	10.8	15	2	1/20	0.45	2	1/20	0.5
AS*S9516ZNA***	208-230/60/1	12.20	69	16.4	25	2	1/20	0.45	2	1/20	0.5
AS*S9516ZFA***	208-230/60/3	9.30	60	12.8	20	2	1/20	0.45	2	1/20	0.5
AS*S9520ZNA***	208-230/60/1	16.00	97	21.1	35	2	1/20	0.45	2	1/20	0.5
AS*S9520ZFA***	208-230/60/3	11.20	95	15.1	25	2	1/20	0.45	2	1/20	0.5
AS*S9522ZNA***	208-230/60/1	16.70	97	22.1	35	2	1/20	0.45	2	1/20	0.5
AS*S9522ZFA***	208-230/60/3	11.20	95	15.2	25	2	1/20	0.45	2	1/20	0.5

*Add .21 Amps for Heated Receiver

DOE AWEF (AHRI 1250)

AWEF Table	Model Number	Indoor	Outdoor
R-404A	AS*R9510Z****	5.61	8.28
	AS*R9512Z****	5.69	8.32
	AS*S9516Z****	6.17	9.28
	AS*S9520Z****	5.79	7.99
	AS*S9522Z****	5.61	8.67
R-449A / R-448A	AS*R9510Z****	5.61	8.31
	AS*R9512Z****	5.73	8.08
	AS*S9516Z****	5.70	9.10
	AS*S9520Z****	5.79	7.99
	AS*S9522Z****	5.61	8.49
R-452A	AS*R9510Z****	5.61	8.09
	AS*R9512Z****	5.61	8.08
	AS*S9516Z****	5.82	8.71
	AS*S9520Z****	5.61	8.17
	AS*S9522Z****	5.61	8.54

1-1/4 to 2-4/5 HP Medium Temperature Platform (Tube Fin)

Performance Tables (R-404A)

80°F AMBIENT						
Model Number	Suction Temperature (SST)					
	30°F	25°F	20°F	10°F	0°F	-10°F
AS*R9510Z*****	15,591	14,027	13,236	10,345	7,838	5,703
AS*R9512Z*****	20,898	18,964	18,050	14,337	10,997	8,017
AS*S9516Z*****	22,276	20,577	19,956	16,518	13,286	10,245
AS*S9520Z*****	27,719	25,492	24,642	20,363	16,523	13,106
AS*S9522Z*****	30,539	28,187	27,332	22,674	18,376	14,421

90°F AMBIENT						
Model Number	Suction Temperature (SST)					
	30°F	25°F	20°F	10°F	0°F	-10°F
AS*R9510Z*****	13,741	12,309	11,565	8,960	6,734	4,880
AS*R9512Z*****	18,606	16,823	15,952	12,564	9,547	6,885
AS*S9516Z*****	20,340	18,768	18,184	15,024	12,064	9,295
AS*S9520Z*****	25,346	23,300	22,520	18,625	15,168	12,130
AS*S9522Z*****	27,835	25,668	24,870	20,611	16,707	13,142

95°F AMBIENT						
Model Number	Suction Temperature (SST)					
	30°F	25°F	20°F	10°F	0°F	-10°F
AS*R9510Z*****	12,816	11,451	10,730	8,266	6,183	4,469
AS*R9512Z*****	17,461	15,753	14,902	11,678	8,822	6,321
AS*S9516Z*****	19,371	17,864	17,298	14,275	11,453	8,820
AS*S9520Z*****	24,160	22,203	21,457	17,757	14,490	11,643
AS*S9522Z*****	26,484	24,409	23,640	19,579	15,872	12,504

100°F AMBIENT						
Model Number	Suction Temperature (SST)					
	30°F	25°F	20°F	10°F	0°F	-10°F
AS*R9510Z*****	11,890	10,592	9,893	7,573	5,631	4,058
AS*R9512Z*****	16,315	14,683	13,853	10,792	8,097	5,755
AS*S9516Z*****	18,403	16,960	16,412	13,528	10,842	8,344
AS*S9520Z*****	22,974	21,107	20,396	16,888	13,813	11,155
AS*S9522Z*****	25,132	23,150	22,409	18,548	15,037	11,864

110°F AMBIENT						
Model Number	Suction Temperature (SST)					
	30°F	25°F	20°F	10°F	0°F	-10°F
AS*R9510Z*****	10,040	8,874	8,222	6,187	4,528	3,235
AS*R9512Z*****	14,023	12,543	11,755	9,019	6,646	4,625
AS*S9516Z*****	16,466	15,152	14,640	12,033	9,620	—
AS*S9520Z*****	20,601	18,914	18,272	15,152	12,458	—
AS*S9522Z*****	22,428	20,631	19,947	16,484	13,368	—

*All capacity data is at dew point conditions

*Return gas 40°F below 20°F Evaporator and 65°F above 20°F evaporator, Sub Cooling 5°F

*Medium temperature evaporating temperature range is from -10°F to +45°F

Performance Tables (R-448A / R-449A)

80°F AMBIENT						
Model Number	Suction Temperature (SST)					
	30°F	25°F	20°F	10°F	0°F	-10°F
AS*R9510Z*****	14,201	12,553	11,596	8,758	6,463	4,701
AS*R9512Z*****	19,105	17,108	15,995	12,303	9,071	6,289
AS*S9516Z*****	20,765	18,929	18,067	14,641	11,628	9,015
AS*S9520Z*****	23,673	21,573	20,593	16,729	13,378	10,526
AS*S9522Z*****	26,702	24,512	23,520	19,116	14,954	11,021

90°F AMBIENT						
Model Number	Suction Temperature (SST)					
	30°F	25°F	20°F	10°F	0°F	-10°F
AS*R9510Z*****	12,604	11,039	10,092	7,433	5,315	3,729
AS*R9512Z*****	17,273	15,395	14,321	10,885	7,907	5,378
AS*S9516Z*****	19,321	17,574	16,737	13,504	10,681	8,255
AS*S9520Z*****	21,976	19,991	19,052	15,436	12,330	—
AS*S9522Z*****	24,765	22,704	21,755	17,625	13,735	—

95°F AMBIENT						
Model Number	Suction Temperature (SST)					
	30°F	25°F	20°F	10°F	0°F	-10°F
AS*R9510Z*****	11,806	10,282	9,339	6,770	4,741	3,242
AS*R9512Z*****	16,356	14,539	13,484	10,176	7,326	4,923
AS*S9516Z*****	18,599	16,897	16,072	12,935	10,206	7,876
AS*S9520Z*****	21,127	19,200	18,281	14,789	11,806	—
AS*S9522Z*****	23,797	21,800	20,872	16,879	13,125	—

100°F AMBIENT						
Model Number	Suction Temperature (SST)					
	30°F	25°F	20°F	10°F	0°F	-10°F
AS*R9510Z*****	11,008	9,526	8,588	6,108	4,168	2,756
AS*R9512Z*****	15,440	13,683	12,647	9,467	6,743	4,467
AS*S9516Z*****	17,878	16,220	15,407	12,366	9,732	7,496
AS*S9520Z*****	20,278	18,409	17,512	14,142	—	—
AS*S9522Z*****	22,829	20,896	19,989	16,133	—	—

110°F AMBIENT						
Model Number	Suction Temperature (SST)					
	30°F	25°F	20°F	10°F	0°F	-10°F
AS*R9510Z*****	9,411	8,012	7,084	4,783	3,019	1,783
AS*R9512Z*****	13,608	11,970	10,972	8,049	5,580	3,556
AS*S9516Z*****	16,434	14,866	14,078	11,228	8,785	—
AS*S9520Z*****	18,580	16,828	15,970	—	—	—
AS*S9522Z*****	20,892	19,088	18,222	—	—	—

Performance Tables (R-452A)

80°F AMBIENT						
Model Number	Suction Temperature (SST)					
	30°F	25°F	20°F	10°F	0°F	-10°F
AS*R9510Z*****	14,174	12,682	11,880	9,174	6,863	4,938
AS*R9512Z*****	19,848	17,889	16,876	13,194	9,933	7,083
AS*S9516Z*****	21,079	19,234	18,427	15,041	12,129	9,678
AS*S9520Z*****	25,702	23,286	22,183	18,029	14,708	12,202
AS*S9522Z*****	28,198	25,728	24,627	20,001	15,932	12,403

90°F AMBIENT						
Model Number	Suction Temperature (SST)					
	30°F	25°F	20°F	10°F	0°F	-10°F
AS*R9510Z*****	12,595	11,184	10,388	7,857	5,720	3,966
AS*R9512Z*****	17,747	15,920	14,942	11,545	8,567	5,996
AS*S9516Z*****	19,435	17,698	16,921	13,769	11,086	8,862
AS*S9520Z*****	24,076	21,749	20,656	16,694	13,563	11,245
AS*S9522Z*****	25,832	23,538	22,505	18,253	14,556	11,395

95°F AMBIENT						
Model Number	Suction Temperature (SST)					
	30°F	25°F	20°F	10°F	0°F	-10°F
AS*R9510Z*****	11,805	10,435	9,641	7,198	5,148	3,480
AS*R9512Z*****	16,696	14,936	13,975	10,721	7,884	5,454
AS*S9516Z*****	18,613	16,930	16,169	13,132	10,565	8,455
AS*S9520Z*****	23,263	20,981	19,894	16,028	12,991	10,766
AS*S9522Z*****	24,650	22,443	21,443	17,380	13,867	10,891

100°F AMBIENT						
Model Number	Suction Temperature (SST)					
	30°F	25°F	20°F	10°F	0°F	-10°F
AS*R9510Z*****	11,015	9,686	8,895	6,540	4,575	2,995
AS*R9512Z*****	15,645	13,951	13,008	9,897	7,201	4,911
AS*S9516Z*****	17,791	16,162	15,417	12,496	10,043	8,046
AS*S9520Z*****	22,450	20,212	19,131	15,360	12,418	10,288
AS*S9522Z*****	23,467	21,347	20,381	16,505	13,179	—

110°F AMBIENT						
Model Number	Suction Temperature (SST)					
	30°F	25°F	20°F	10°F	0°F	-10°F
AS*R9510Z*****	9,435	8,187	7,403	5,222	3,432	2,023
AS*R9512Z*****	13,544	11,983	11,074	8,247	5,835	3,825
AS*S9516Z*****	16,147	14,625	13,913	11,223	9,000	7,231
AS*S9520Z*****	20,824	18,675	17,606	14,026	11,274	—
AS*S9522Z*****	21,101	19,157	18,259	14,758	—	—