



June 11, 2010

Tecumseh Compressor Company

Indoor Condensing Units

Model: AWA2448ZDXC

BoM: 2T1118-2

R-404A

1 HP

AIR COOLED

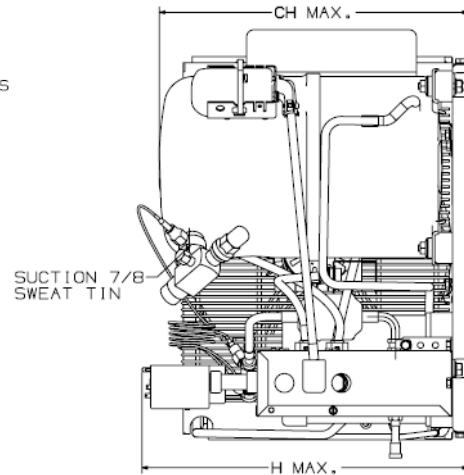
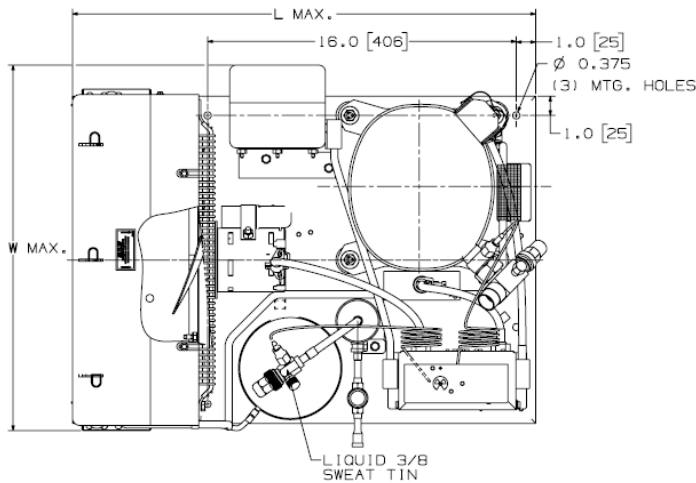

Model	Dimensions, inches				Line Connection*		Pump down	Air	Oil Ch	Gr. Wt.
	L	W	H	CH	Suction	Liquid	90°F 90%	SCFM	Oz.	Lbs.
AWA2448ZDXC	24.0	19.0	15.0	14.2	5/8" S	3/8" S	6.3 lbs	615	38.0	119

* F = Flare, S = Solder, RF or RS = Rotolock with Flare or Solder Connections, C = Compression Fitting

Evaporator T,		Ambient Temperatures											
		90°F				100°F				110°F			
°F	PSIG	BTUH	Watts	Head	Cond T	BTUH	Watts	Head	Cond T	BTUH	Watts	Head	Cond T
-40	4.3	1388	948	228	97	871	876	261	107	455	856	290	114
-35	6.8	1888	1017	232	98	1358	956	264	108	901	941	295	116
-30	9.6	2418	1091	237	100	1862	1040	269	109	1359	1029	301	117
-25	12.6	2978	1171	243	102	2384	1128	275	110	1831	1120	308	119
-20	16.0	3568	1256	250	104	2922	1219	282	112	2316	1215	316	121
-15	19.6	4188	1347	259	106	3478	1314	290	114	2814	1312	324	123
-10	23.6	4838	1444	269	109	4051	1413	300	117	3325	1413	334	125
-5	27.9	5517	1545	280	112	4641	1515	311	119	3848	1516	345	127
0	32.6	6227	1653	292	115	5249	1622	324	122	4385	1623	356	130
5	37.7	6966	1765	306	118	5874	1732	337	125	4935	1733	368	132
10	43.2	7736	1883	321	121	6516	1846	352	129	5497	1846	382	135

60 Hz Performance

Return gas temp. 40°F, 5°F sub cooling

