



June 11, 2010

# Tecumseh Compressor Company

## Indoor Condensing Units

Model: AVA2510ZXNXC

BoM: 2T2116-2

R-404A

2 1/2 HP

AIR COOLED

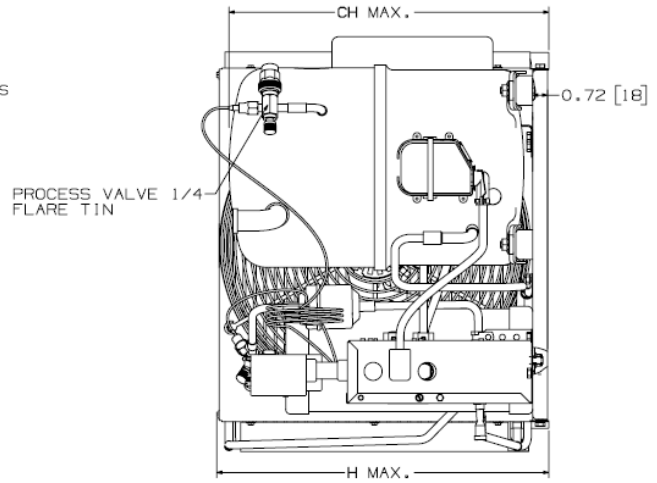
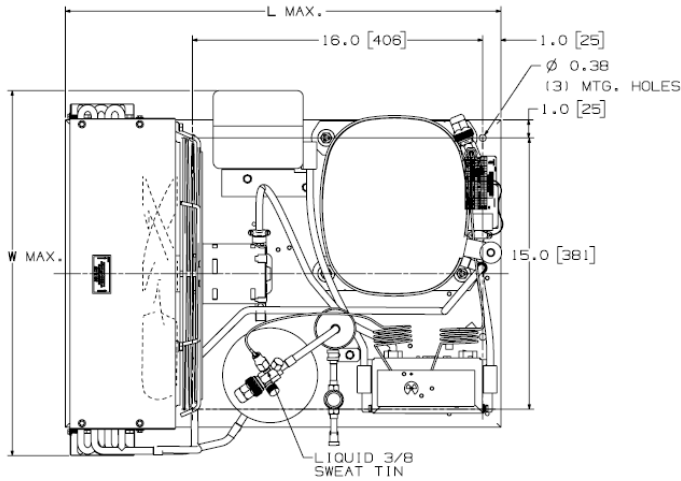

Model	Dimensions, inches				Line Connection*		Pump down	Air	Oil Ch	Gr. Wt.
	L	W	H	CH	Suction	Liquid	90°F 90%	SCFM	Oz.	Lbs.
<b>AVA2510ZXNXC</b>	24.0	20.2	16.1	15.5	3/4" S	3/8" S	10.8 lbs	804	54.0	140

\* F = Flare, S = Solder, RF or RS = Rotolock with Flare or Solder Connections, C = Compression Fitting

Evaporator T,		Ambient Temperatures															
		80°F				90°F				100°F				110°F			
°F	PSIG	BTUH	Watts	Head	Cond T	BTUH	Watts	Head	Cond T	BTUH	Watts	Head	Cond T	BTUH	Watts	Head	Cond T
-40	4.3	4582	1610	209	91	3592	1522	237	100	2884	1486	267	108	2329	1370	303	118
-35	6.8	5755	1777	217	94	4675	1703	246	102	3839	1655	276	111	3088	1558	312	120
-30	9.6	6928	1956	227	97	5751	1894	256	105	4785	1839	287	114	3856	1758	321	122
-25	12.6	8100	2146	237	100	6822	2097	267	108	5721	2037	298	116	4633	1971	332	125
-20	16.0	9272	2347	248	103	7887	2311	278	111	6647	2250	310	119	5417	2196	344	127
-15	19.6	10443	2560	260	106	8946	2536	291	115	7564	2477	323	122	6210	2434	357	130
-10	23.6	11613	2784	274	110	9999	2772	305	118	8471	2719	337	126	7011	2684	370	133
-5	27.9	12784	3020	288	113	11046	3019	319	121	9368	2976	352	129	7820	2947	385	136
0	32.6	13953	3267	303	117	12088	3277	335	125	10256	3248	368	132	8638	3222	401	139
5	37.7	15122	3526	318	121	13123	3546	351	129	11135	3534	385	136	9463	3510	418	143
10	43.2	16291	3796	335	125	14153	3826	369	132	12003	3835	403	140	10298	3810	436	146

### 60 Hz Performance

Return gas temp. 40°F, 5°F sub cooling

