



# TECUMSEH OUTDOOR CONDENSING UNIT

**Model** AWA9512ZXNLN  
**BOM** 32L1451-6U

---

**Air Cooled** 1 1/4 HP  
**Application** Commercial Temp  
**Refrigerant** R404A  
**Volts-Hz-Ph.** 208-230/60/1

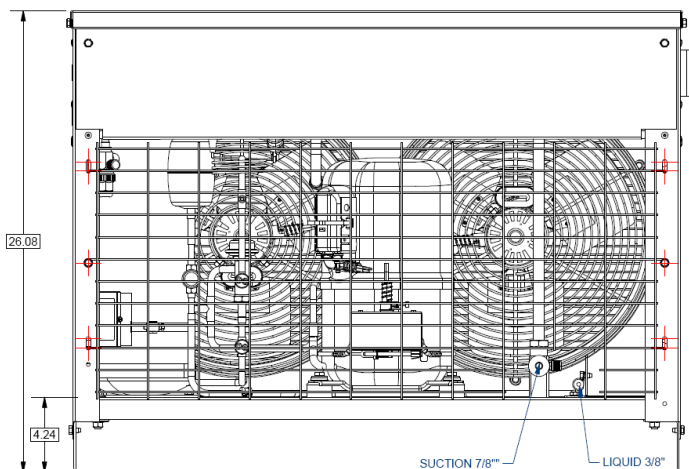
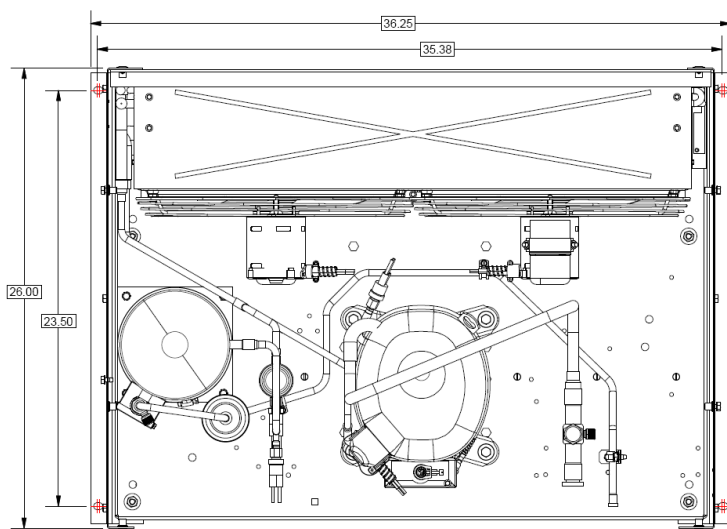

AWA9512ZXNLN	Overall Dimensions, inch (mm)			Line connections		Pump down 90% @ 90°F	Air flow	Oil Ch.	Gross weight
	L	W	H	Suction	Liquid		SCFM	Oz.	Lbs. (kg)
	26.43 (671)	36.25 (921)	26.08 (662)	7/8"	3/8"	19.80 lbs.	1750	38.6	320 (145)

Factory charge 20 psig dry air, **MUST BE EVACUATED**

Evaporator		Ambient Temperatures														
		90°F			95°F			100°F			110°F			115°F		
T, °F	PSIG	BTUH	Watts	Cond T	BTUH	Watts	Cond T	BTUH	Watts	Cond T	BTUH	Watts	Cond T	BTUH	Watts	Cond T
-10	23.9	4500	1620	99	4100	1590	103	3700	1560	108	2800	1510	117	2400	1480	121
-5	27.5	5700	1660	101	5200	1630	105	4700	1610	109	3800	1560	118	3300	1540	122
0	32.1	6900	1720	103	6400	1700	107	5800	1690	111	4700	1650	120	4200	1630	124
5	37.0	8200	1810	104	7600	1800	108	7000	1780	112	5800	1760	121	5200	1740	125
10	42.4	9600	1920	106	8900	1910	110	8200	1900	114	6900	1880	122	6200	1870	126
15	48.2	11000	2030	108	10300	2020	111	9500	2020	115	8000	2010	124	7200	2010	128
<b>20</b>	<b>54.5</b>	<b>12500</b>	<b>2140</b>	<b>109</b>	<b>11600</b>	<b>2140</b>	<b>113</b>	<b>10800</b>	<b>2140</b>	<b>117</b>	<b>9200</b>	<b>2150</b>	<b>125</b>	<b>8300</b>	<b>2150</b>	<b>129</b>
25	61.2	14000	2240	111	13100	2250	115	12200	2260	118	10400	2280	127	9500	2290	130
30	68.4	15600	2330	113	14600	2350	116	13600	2360	120	11600	2400	128	10700	2410	132
35	76.1	17200	2390	114	16100	2420	118	15100	2440	122	12900	2470	129	11900	2520	133
40	84.4	18900	2430	116	17700	2460	119	16600	2500	123	14300	2530	131	13100	2600	134
45	93.2	20600	2420	118	19300	2470	121	18100	2510	125	15800	2560	133	14400	2640	136

Performance @ 60 Hz, Return gas 40°F below 20°F Evaporator and 65°F above 20°F evaporator, Sub Cooling 5°F

**Parts/Specifications**

<b>Unit BOM</b>	<b>32L1451-6U</b>	Fan Motor	810F050C20	Adjustable Fan Control	14955874
<b>Unit MODEL</b>	<b>AWA9512ZXNLN</b>	Replacement Fan Motor	50W230	Fixed Fan Control	----
		Fan Motor Qty	2		
Refrigeration Range	-10°F to 45°F	Fan Motor RLA	0.7	Defrost Timer	LTCCG-T1
Design Pressure Low / High	181 / 450	Fan Blade	51568-1	Electric Defrost Timer	----
Volts - HZ - Ph	208-230V ~ 60HZ	Fan Guard	70831		
Voltage Range	187 - 253			Receiver Heater	-----
Min. Circuit Ampacity	14.91	Shroud	70648-2	Receiver Heater Thermostat	-----
Max. Fuse Size	25	Condenser	50858-1	C/Case Heater	91022-1
Compressor MODEL	AWA9490ZXN	Receiver	51099-2L	Unit Drawing	DGU1918-L021
Compressor BOM	AW616ET-099-A4	Accumulator	----	Wiring Diagram	WD21-205
Compressor LRA	52	Liquid Filter	70139		
Compressor RLA	10.64	Sight Glass	70084-S		
		Suction Filter	----		
OverLoad	Internal				
Replacement Kit - O/L	----	High Pressure Switch	84095-2L		
Relay	8200RVAL98	Low Pressure Control	84026-2		
Replacement Kit - Relay	K71-62	Low Pressure Switch	----		
Run Capacitor	85PR370F17	Head Master Valve	70083		
Replacement Kit Run Cap.	K150-14	Check Valve	----	<b>Loose Optional Items</b>	
Start Capacitor	85PS330D17	Liquid Valve	On the Receiver	Disconnect Switch	LDSG-311
Replacement Kit Start Cap	K146-44	Suction Valve (Base)	56500-K14	Liquid Solenoid	KSVC-285
Contactor	91014H			Hail Louver	LLPG-201

