



Indoor Condensing Unit Technical Datasheet

February 9, 2023
Revision: REV A

Tecumseh

Model: AGB4563ECZXM

BoM: 392A5058-1

R-22

5 HP

AIRCOOLED

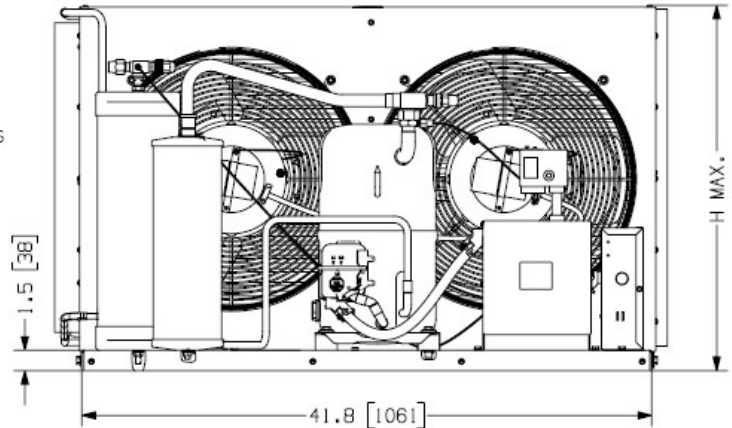
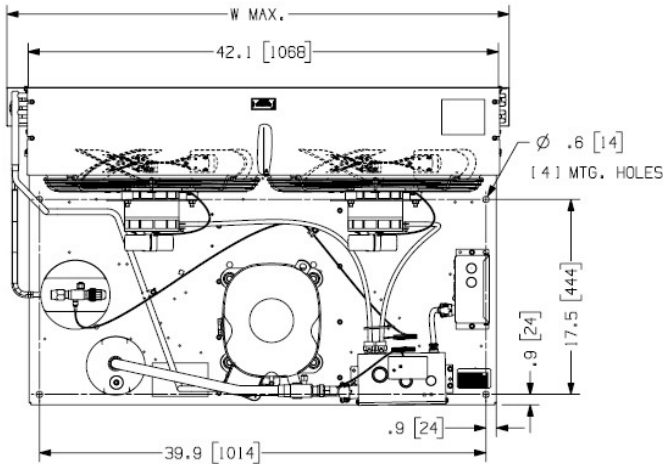

Model	Dimensions, inches				Line Connection*		Pumpdown	Air	Oil Ch	Gr. Wt.
	L	W	H	CH	Suction	Liquid	90 °F 90%	SCFM	Oz.	Lbs.
AGB4563ECZXM	28.5	44.9	26.8	18.1	7/8" S	5/8" S	34.7 lbs	4200	60	340

* F = Flare, S = Solder, RF or RS = Rotolock with Flare or Solder Connections, C = Compression Fitting

Evaporator T,		Ambient Temperatures								
		90°F			100°F			110°F		
°F	PSIG	BTUH	Watts	Cond T	BTUH	Watts	Cond T	BTUH	Watts	Cond T
20	43.0	42000	5000	108	37600	5120	117	33100	5220	125
30	54.8	50000	5800	112	45500	5910	120	41000	6080	128
40	68.5	58000	6500	116	54100	6700	124	49700	6920	132
45	76.0	62450	6900	119	58500	7210	127	53800	7370	134
50	84.0	65300	7300	121	61450	7600	129	57200	7820	137

60 Hz Performance

Return gas temp. 65°F and 5°F sub-cooling

