

ITEM	PART NUMBER
A	320-10147
B	14963285
C	14947663
D	580-10244
E	14963571

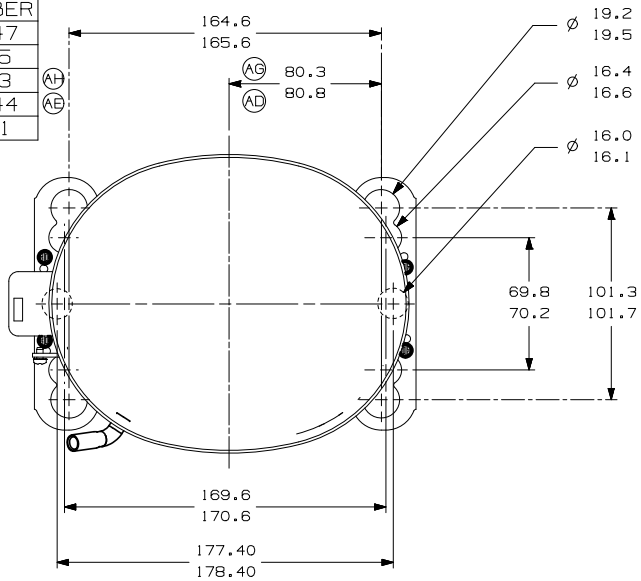

- AUXILIARY VIEW -
FASTENING DIMENSIONS

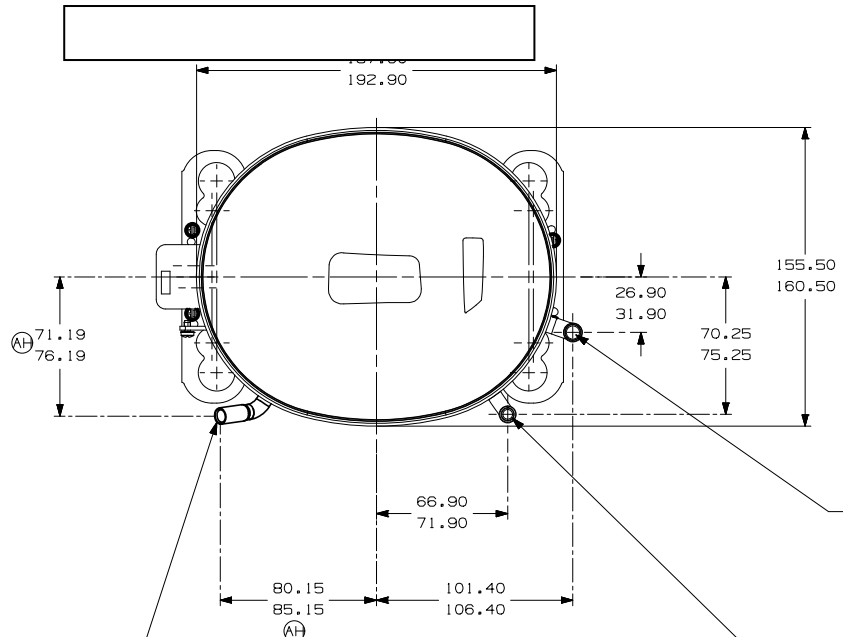

C - (COPPER) PROCESS TUBE
GAGE I.D. TO 6.45-6.55
× 15.00-17.00 DEEP.

E - (COPPER) SUCTION TUBE
GAGE I.D. TO 8.00-8.10
× 15.00-17.00 DEEP.

D - (COPPER) DISCHARGE TUBE
GAGE I.D. TO 6.45-6.55
× 15.00-17.00 DEEP.

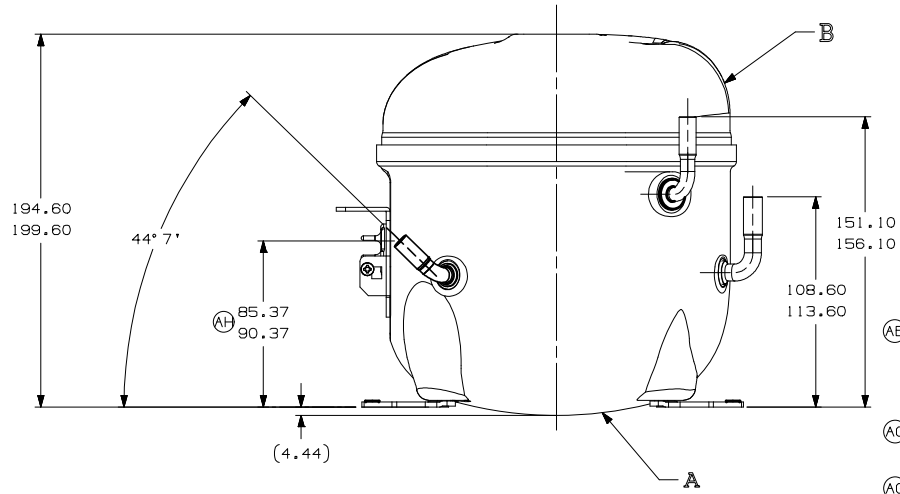
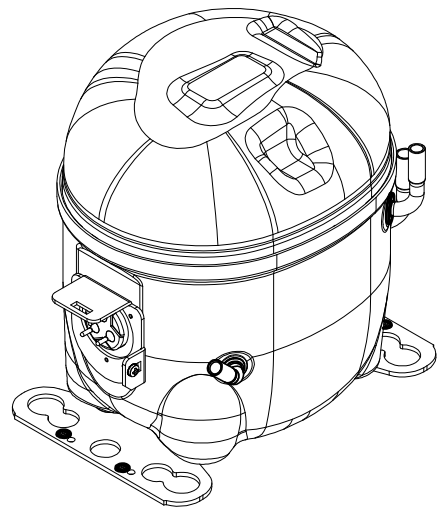

NOTES:

- IF SPECIFIED IN BM. ASSEMBLE PARTS AS SHOWN.
- SEE SPEC. "A-B" & A-C FOR PROCESS.
- THERE CAN BE NO CREASES IN THE TUBES. (CREASES ARE SIGNS OR MARKS THAT ARE IN SOMETHING THAT BENDS)
- AFTER THE FOLDS IN THE TUBES, CANNOT BE ACCELERATED TO AREA EXCEEDING 30%.
- TUBES OF SUCTION, DISCHARGE AND PROCESS MUST BE FREE OF INK ON 15.8mm (5/8") FROM TOP OF THE TUBES AS SPEC. T.P.Co. A-B4.
- FOR SUPPLIER ENVIRONMENTAL REGULATORY REQUIREMENTS, SEE TECUMSEH GLOBAL SPEC. 08.

(AB)
(AC)
(AG)

REV.	DESCRIPTION	DATE
B5	ERA 91.60-96.60	03-09-20
D4	ERA 66.60-91.60	03-09-20
E5	ERA 72.10-77.10	03-09-20
F8	ERA 14963573	03-09-20
A/2	ALTERADA MEDIDA 14-02-19	03-09-20
A/3	ALTERADA MEDIDA 14-02-19	03-09-20
A/4	ALTERADA MEDIDA 14-02-19	03-09-20
A/5	ALTERADA MEDIDA 14-02-19	03-09-20
A/6	ALTERADA MEDIDA 14-02-19	03-09-20
A/7	ALTERADA MEDIDA 14-02-19	03-09-20
A/8	ALTERADA MEDIDA 14-02-19	03-09-20
A/9	ALTERADA MEDIDA 14-02-19	03-09-20
A/10	ALTERADA MEDIDA 14-02-19	03-09-20
A/11	ALTERADA MEDIDA 14-02-19	03-09-20
A/12	ALTERADA MEDIDA 14-02-19	03-09-20
A/13	ALTERADA MEDIDA 14-02-19	03-09-20
A/14	ALTERADA MEDIDA 14-02-19	03-09-20
A/15	ALTERADA MEDIDA 14-02-19	03-09-20
A/16	ALTERADA MEDIDA 14-02-19	03-09-20
A/17	ALTERADA MEDIDA 14-02-19	03-09-20
A/18	ALTERADA MEDIDA 14-02-19	03-09-20
A/19	ALTERADA MEDIDA 14-02-19	03-09-20
A/20	ALTERADA MEDIDA 14-02-19	03-09-20
A/21	ALTERADA MEDIDA 14-02-19	03-09-20
A/22	ALTERADA MEDIDA 14-02-19	03-09-20
A/23	ALTERADA MEDIDA 14-02-19	03-09-20
A/24	ALTERADA MEDIDA 14-02-19	03-09-20
A/25	ALTERADA MEDIDA 14-02-19	03-09-20
A/26	ALTERADA MEDIDA 14-02-19	03-09-20
A/27	ALTERADA MEDIDA 14-02-19	03-09-20
A/28	ALTERADA MEDIDA 14-02-19	03-09-20
A/29	ALTERADA MEDIDA 14-02-19	03-09-20
A/30	ALTERADA MEDIDA 14-02-19	03-09-20
A/31	ALTERADA MEDIDA 14-02-19	03-09-20
A/32	ALTERADA MEDIDA 14-02-19	03-09-20
A/33	ALTERADA MEDIDA 14-02-19	03-09-20
A/34	ALTERADA MEDIDA 14-02-19	03-09-20
A/35	ALTERADA MEDIDA 14-02-19	03-09-20
A/36	ALTERADA MEDIDA 14-02-19	03-09-20
A/37	ALTERADA MEDIDA 14-02-19	03-09-20
A/38	ALTERADA MEDIDA 14-02-19	03-09-20
A/39	ALTERADA MEDIDA 14-02-19	03-09-20
A/40	ALTERADA MEDIDA 14-02-19	03-09-20
A/41	ALTERADA MEDIDA 14-02-19	03-09-20
A/42	ALTERADA MEDIDA 14-02-19	03-09-20
A/43	ALTERADA MEDIDA 14-02-19	03-09-20
A/44	ALTERADA MEDIDA 14-02-19	03-09-20
A/45	ALTERADA MEDIDA 14-02-19	03-09-20
A/46	ALTERADA MEDIDA 14-02-19	03-09-20
A/47	ALTERADA MEDIDA 14-02-19	03-09-20
A/48	ALTERADA MEDIDA 14-02-19	03-09-20
A/49	ALTERADA MEDIDA 14-02-19	03-09-20
A/50	ALTERADA MEDIDA 14-02-19	03-09-20
A/51	ALTERADA MEDIDA 14-02-19	03-09-20
A/52	ALTERADA MEDIDA 14-02-19	03-09-20
A/53	ALTERADA MEDIDA 14-02-19	03-09-20
A/54	ALTERADA MEDIDA 14-02-19	03-09-20
A/55	ALTERADA MEDIDA 14-02-19	03-09-20
A/56	ALTERADA MEDIDA 14-02-19	03-09-20
A/57	ALTERADA MEDIDA 14-02-19	03-09-20
A/58	ALTERADA MEDIDA 14-02-19	03-09-20
A/59	ALTERADA MEDIDA 14-02-19	03-09-20
A/60	ALTERADA MEDIDA 14-02-19	03-09-20
A/61	ALTERADA MEDIDA 14-02-19	03-09-20
A/62	ALTERADA MEDIDA 14-02-19	03-09-20
A/63	ALTERADA MEDIDA 14-02-19	03-09-20
A/64	ALTERADA MEDIDA 14-02-19	03-09-20
A/65	ALTERADA MEDIDA 14-02-19	03-09-20
A/66	ALTERADA MEDIDA 14-02-19	03-09-20
A/67	ALTERADA MEDIDA 14-02-19	03-09-20
A/68	ALTERADA MEDIDA 14-02-19	03-09-20
A/69	ALTERADA MEDIDA 14-02-19	03-09-20
A/70	ALTERADA MEDIDA 14-02-19	03-09-20
A/71	ALTERADA MEDIDA 14-02-19	03-09-20
A/72	ALTERADA MEDIDA 14-02-19	03-09-20
A/73	ALTERADA MEDIDA 14-02-19	03-09-20
A/74	ALTERADA MEDIDA 14-02-19	03-09-20
A/75	ALTERADA MEDIDA 14-02-19	03-09-20
A/76	ALTERADA MEDIDA 14-02-19	03-09-20
A/77	ALTERADA MEDIDA 14-02-19	03-09-20
A/78	ALTERADA MEDIDA 14-02-19	03-09-20
A/79	ALTERADA MEDIDA 14-02-19	03-09-20
A/80	ALTERADA MEDIDA 14-02-19	03-09-20
A/81	ALTERADA MEDIDA 14-02-19	03-09-20
A/82	ALTERADA MEDIDA 14-02-19	03-09-20
A/83	ALTERADA MEDIDA 14-02-19	03-09-20
A/84	ALTERADA MEDIDA 14-02-19	03-09-20
A/85	ALTERADA MEDIDA 14-02-19	03-09-20
A/86	ALTERADA MEDIDA 14-02-19	03-09-20
A/87	ALTERADA MEDIDA 14-02-19	03-09-20
A/88	ALTERADA MEDIDA 14-02-19	03-09-20
A/89	ALTERADA MEDIDA 14-02-19	03-09-20
A/90	ALTERADA MEDIDA 14-02-19	03-09-20
A/91	ALTERADA MEDIDA 14-02-19	03-09-20
A/92	ALTERADA MEDIDA 14-02-19	03-09-20
A/93	ALTERADA MEDIDA 14-02-19	03-09-20
A/94	ALTERADA MEDIDA 14-02-19	03-09-20
A/95	ALTERADA MEDIDA 14-02-19	03-09-20
A/96	ALTERADA MEDIDA 14-02-19	03-09-20
A/97	ALTERADA MEDIDA 14-02-19	03-09-20
A/98	ALTERADA MEDIDA 14-02-19	03-09-20
A/99	ALTERADA MEDIDA 14-02-19	03-09-20
A/100	ALTERADA MEDIDA 14-02-19	03-09-20

THIRD ANGLE PROJECTION

UNITS: mm

DRAWING SIZE: A2

REV. A SYMBOLS AS PROCEDURE 2.01.031 TECUMSEH OF BRAZIL

★ = CATEGORY I

▲ = CATEGORY II

■ = CATEGORY III

● = CATEGORY IV

NAME: SALES COMPRESSOR

PARTY NO.: DCAE212

DWN. J. BARBANO	CK. A. MARTINEZ	APR. W. CORREA	SCALE 1:2	PAGE 1/1
DATE 12/09/11	REF.		FAMILY AE2	