

ITEM	PART NUMBER
A	320-10156
B	14963286
C	14947663
D	580-10244
E	14963572

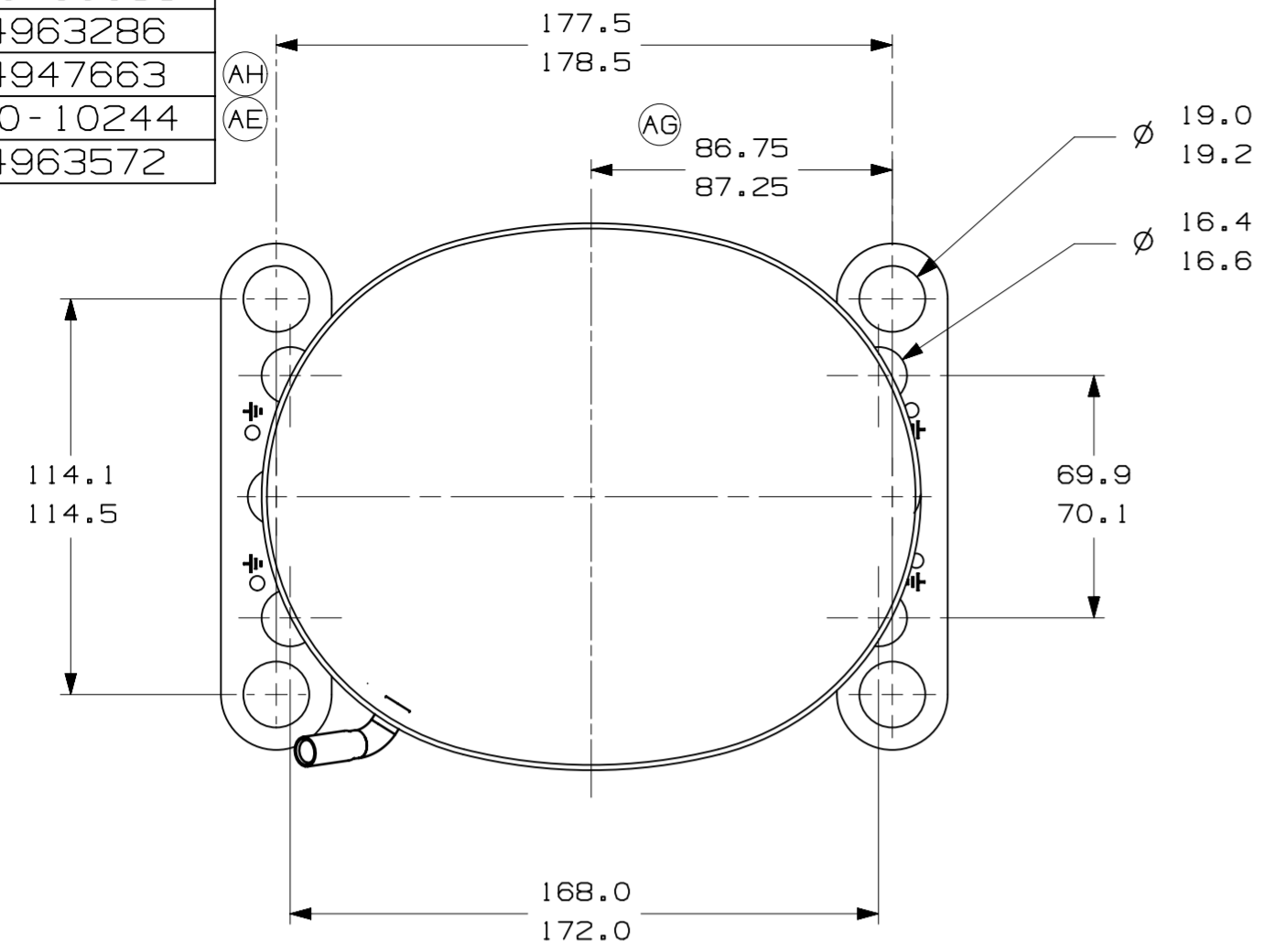

- AUXILIARY VIEW -  
FASTENING DIMENSIONS

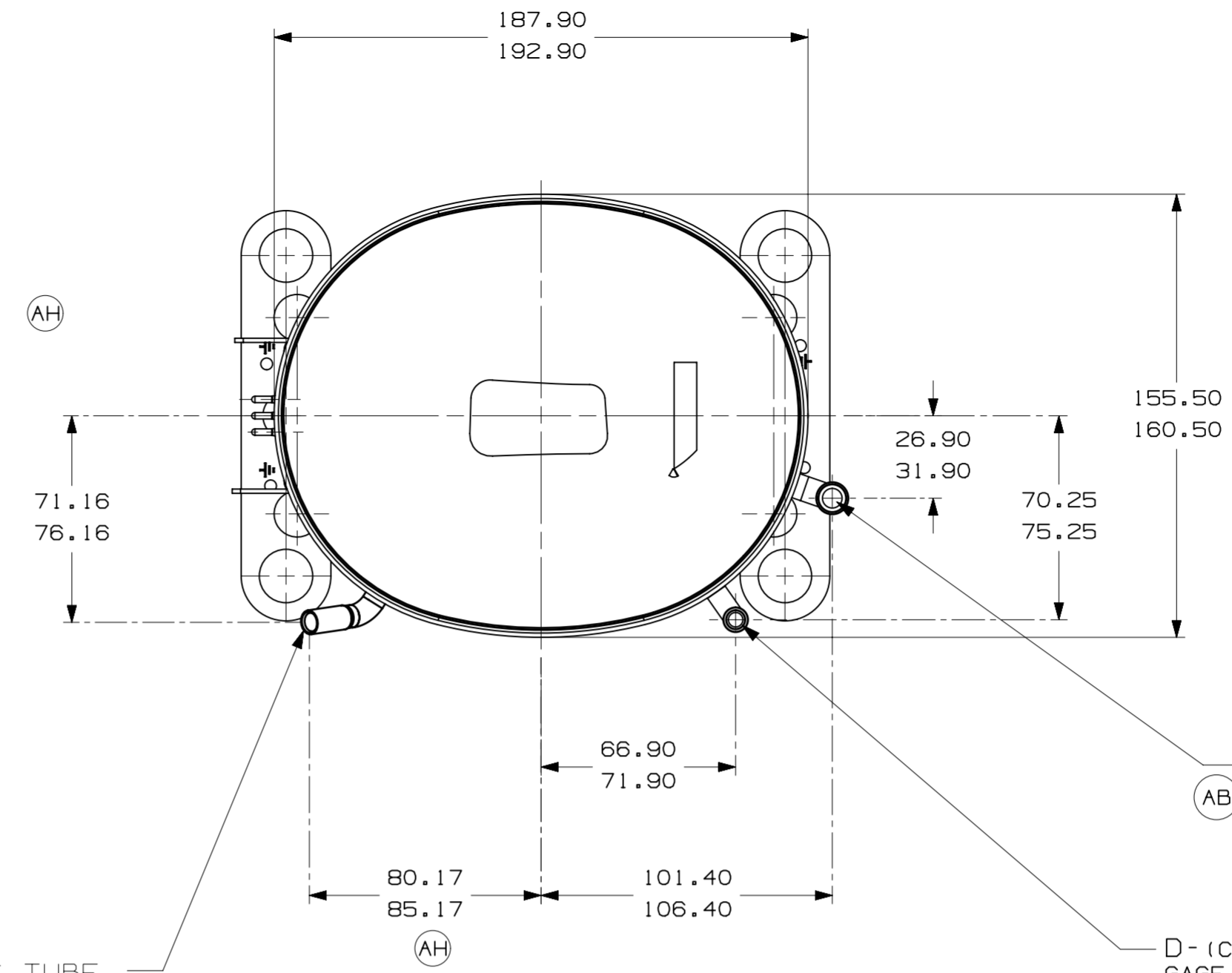

E- (COPPER) SUCTION TUBE  
GAGE I.D. TO 9.6-9.7  
× 15.00-17.00 DEEP.

D- (COPPER) DISCHARGE TUBE  
GAGE I.D. TO 6.45-6.55  
× 13.00-15.00 DEEP.

C- (COPPER) PROCESS TUBE  
GAGE I.D. TO 6.45-6.55  
× 15.00-17.00 DEEP.

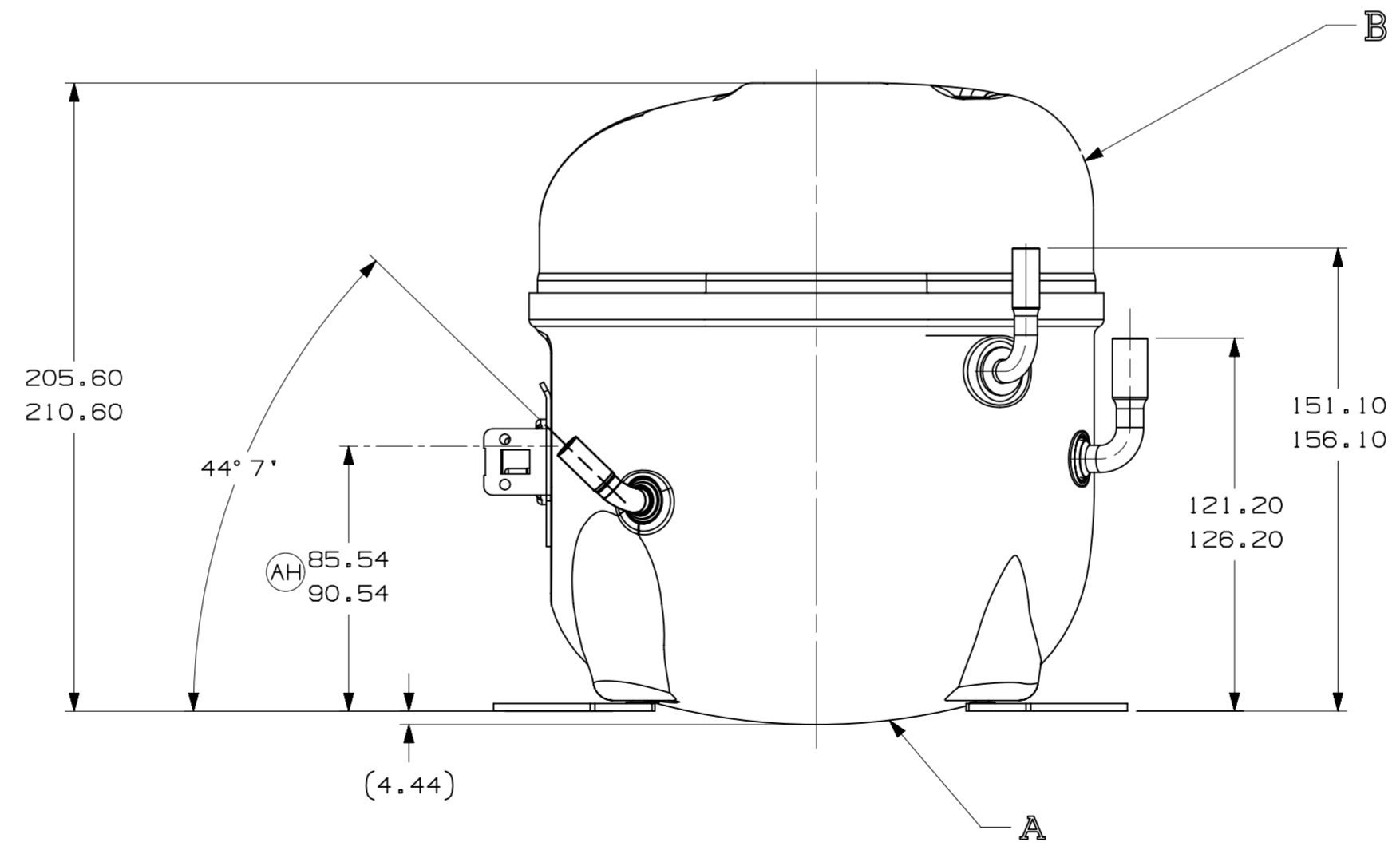
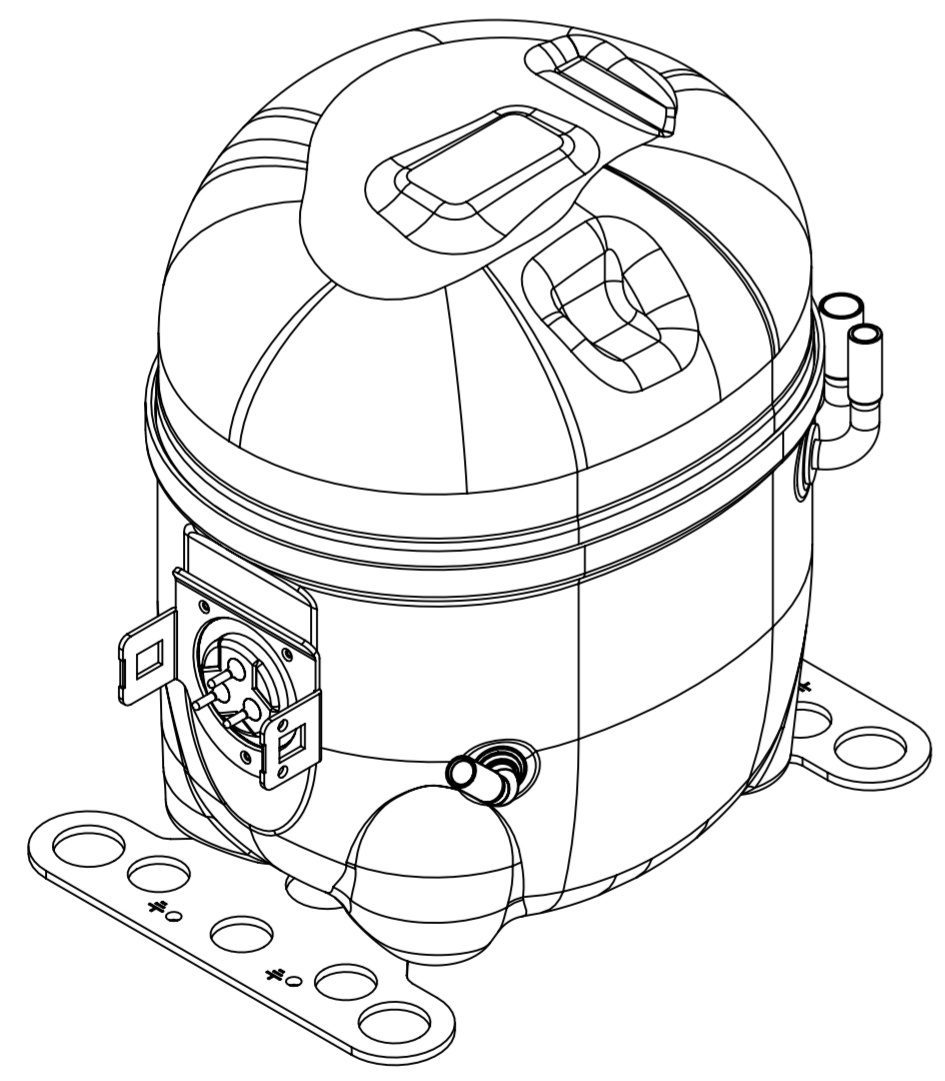

- NOTES:
- IF SPECIFIED IN BM. ASSEMBLE PARTS AS SHOWN.
  - SEE SPEC. "A-B" & A-C FOR PROCESS.
  - THERE CAN BE NO CREASES IN THE TUBES. (CREASES ARE SIGNS OR MARKS THAT ARE IN SOMETHING THAT BENDS)
  - AFTER THE FOLDS IN THE TUBES, CANNOT BE ACCELERATED TO AREA EXCEEDING 30%.
  - TUBES OF SUCTION, DISCHARGE AND PROCESS MUST BE FREE OF INK ON 15.8mm (5/8") FROM TOP OF THE TUBES AS SPEC. T.P.Co. A-B4.
  - FOR SUPPLIER ENVIRONMENTAL REGULATORY REQUIREMENTS, SEE TECUMSEH GLOBAL SPEC. 08.

REV	DATE	BY	CHKD	DESCRIPTION
B5	ERA 91.60-96.60			
D4	ERA 86.60-91.60			
E5	ERA 72.10-77.10			
F8	ERA 14963573			
A/2	ALTERA MEDIDA F77 E ACRES. NOTA 6			
AG	ERA: 88.75-89.25			
AF	RETIRADO DETALHE (AREA ISENTA DE PINTURA)			
AE	F/B ALTERADO TUBO D ERA: 14963519			
AD	N/2 ADDED NOTE			
A/2	REVISADA NOTAS 3 E 4			
A/2	ACRESCENTADA NOTAS 3 E 4			
D2	CORRIGIDO Ø INT. TUBO SUCCAO ERA: Ø 8.00-8.10			
AA	LIBERACAO			

THIRD ANGLE PROJECTION

UNITS: mm

DRAWING SIZE: A2

0. A SYMBOLS AS PROCEDURE 2.01.031 TECUMSEH OF BRAZIL

NAME: SALES COMPRESSOR

PART NO.: DCAE199

SCALE: 1:2

PAGE: 1/1

DATE: 22/09/11

REF.

FAMILY: AE2