

ITEM	PART NUMBER
A	320-10212
B	14963286
C	14947663
D	580-10245
E	14963570

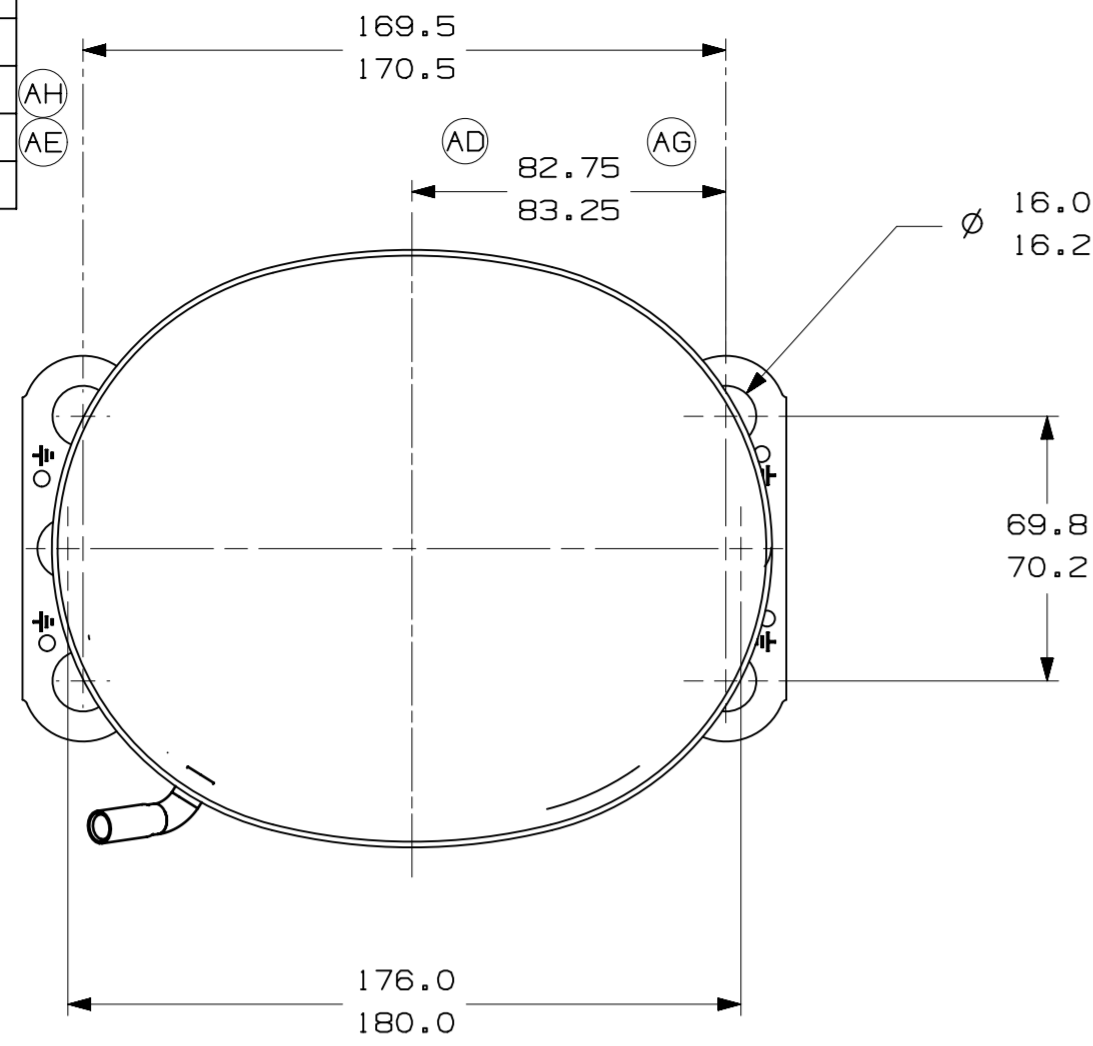

- AUXILIARY VIEW -
FASTENING DIMENSIONS

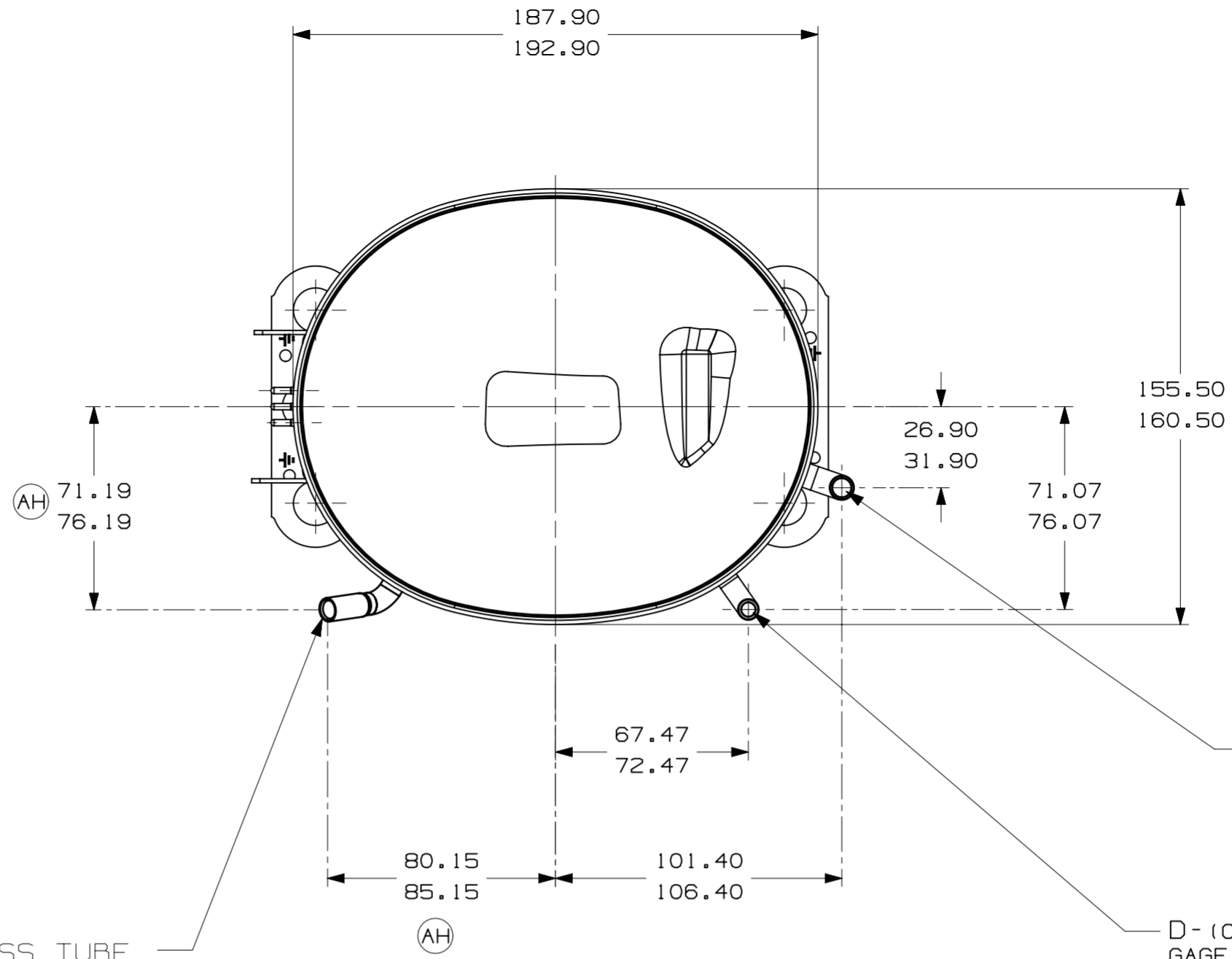

E- (COPPER) SUCTION TUBE
GAGE I.D. TO 6.45-6.55
× 15.00-17.00 DEEP.

D- (COPPER) DISCHARGE TUBE
GAGE I.D. TO 4.92-5.02
× 15.00-17.00 DEEP.

C- (COPPER) PROCESS TUBE
GAGE I.D. TO 6.45-6.55
× 15.00-17.00 DEEP.

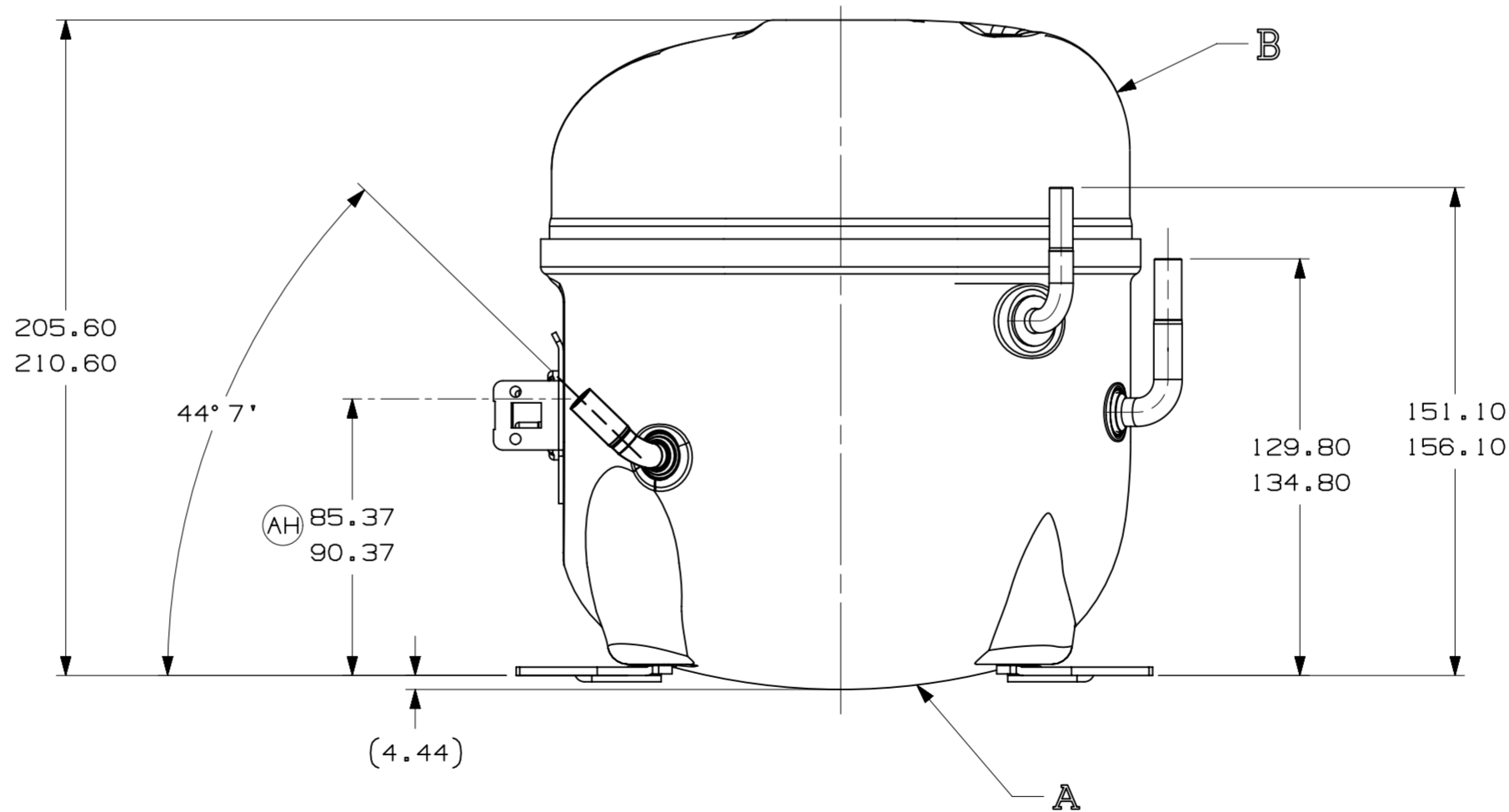
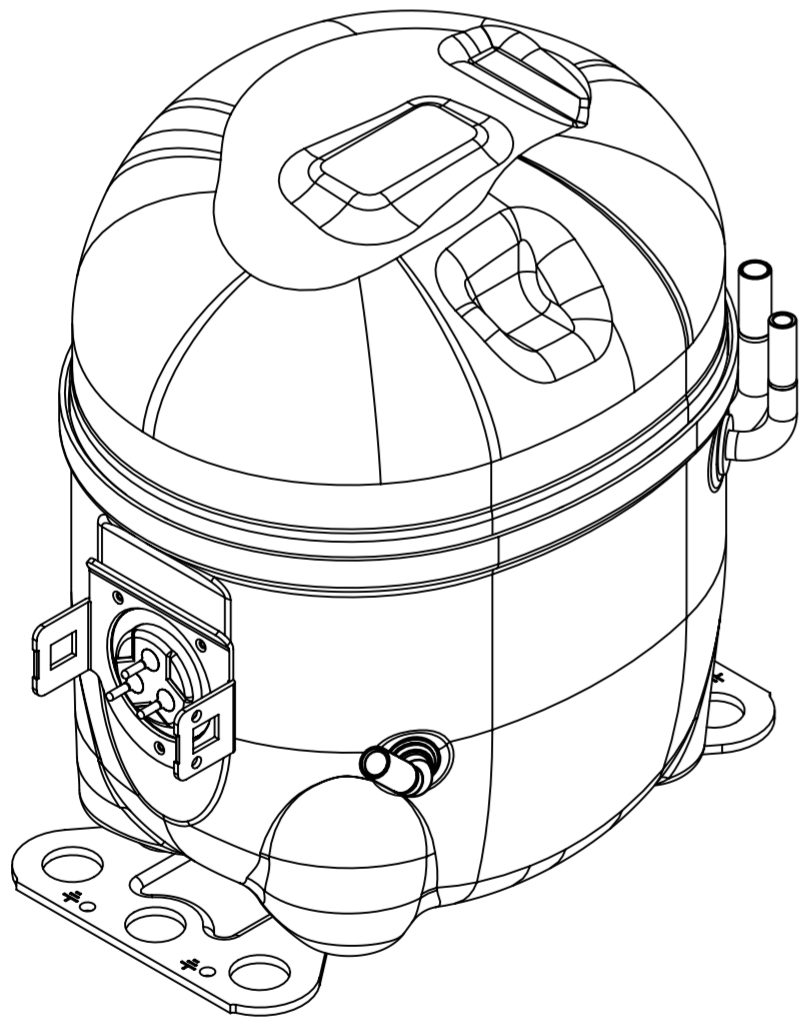

- NOTES:
- IF SPECIFIED IN BM. ASSEMBLE PARTS AS SHOWN.
 - SEE SPEC. "A-B" & A-C FOR PROCESS.
 - THERE CAN BE NO CREASES IN THE TUBES. (CREASES ARE SIGNS OR MARKS THAT ARE IN SOMETHING THAT BENDS)
 - AFTER THE FOLDS IN THE TUBES, CANNOT BE ACCELERATED TO AREA EXCEEDING 30%.
 - TUBES OF SUCTION, DISCHARGE AND PROCESS MUST BE FREE OF INK ON 15.8mm (5/8") FROM TOP OF THE TUBES AS SPEC. T.P.Co. A-B4.
 - FOR SUPPLIER ENVIRONMENTAL REGULATORY REQUIREMENTS, SEE TECUMSEH GLOBAL SPEC. 08.

DATE	DATE	DATE	DATE	DATE	DATE	DATE	DATE	DATE	DATE	DATE
02/05/22	14/02/13	08/06/16	03/03/15	31/01/14	13/09/13	08/06/12	02/03/12			
GM. R6.	PS. RB.	AMP. WC.	PS. RB.	PS. RB.	AMP. WC.	AMP. WC.	PS. A.M.			
ERA 91.60-96.60	ALTERADA MEDIDA ERA: 84.75-85.25 E ACRESC. NOTA 6	RETIRADO DETALHE (AREA ISENTA DE PINTURA)	ALTERADO TUBO D ERA: 14963568	ALTERADA MEDIDA ERA: 182.75-83.25	ADICIONADO NOTA	REVISADA NOTAS 3 E 4	ACRESCENTADA NOTAS 3 E 4	LIBERACAO		
B5	A/2	AF	AE F/B	AD F/7	AC A/2	A/2	A/2	AA		
D4	F/6									
E5										
F8										

THIRD ANGLE PROJECTION

UNITS: mm

DRAWING SIZE: A2

0. A. SYMBOLS AS PROCEDURE 2.01.031 TECUMSEH OF BRAZIL

NAME: SALES COMPRESSOR

PART NO.: DCAE138

SCALE: 1:2

PAGE: 1/1

DATE: 23/02/12

REF.

FAMILY: AE2