

ITEM	PART NUMBER
A	320-10116
B	14963285
C	14947663
D	14963519
E	14963571

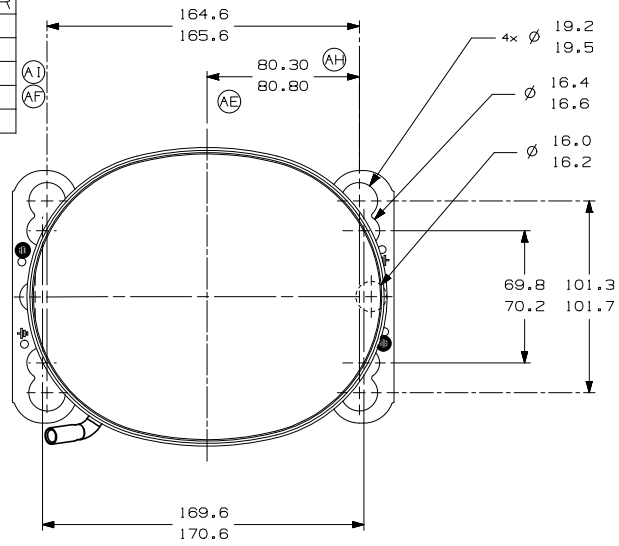

- AUXILIARY VIEW -  
FASTENING DIMENSIONS

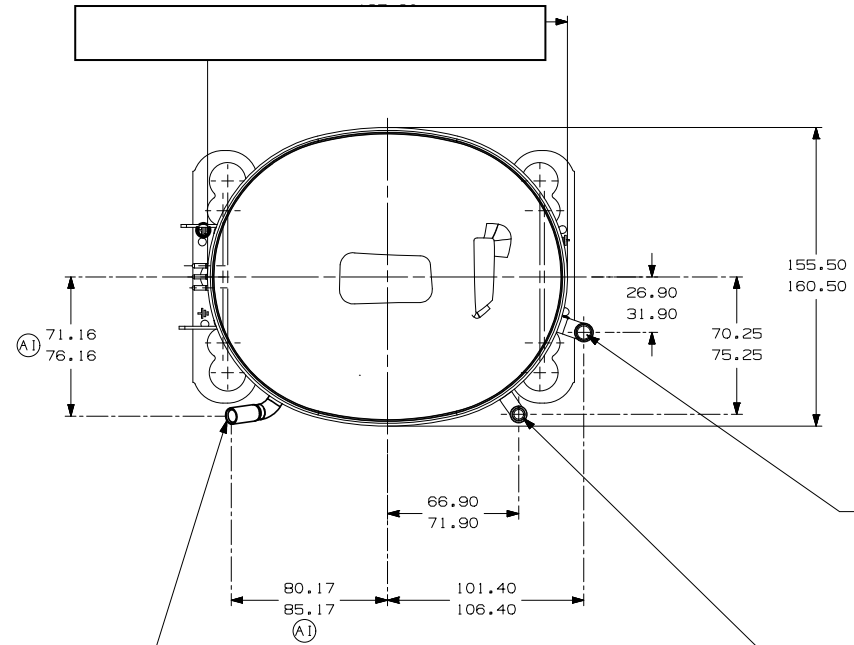

E - (COPPER) SUCTION TUBE  
GAGE I.D. TO 8.00-8.10  
x 15.00-17.00 DEEP.

D - (COPPER) DISCHARGE TUBE  
GAGE I.D. TO 6.45-6.55  
x 15.00-17.00 DEEP.

C - (COPPER) PROCESS TUBE  
GAGE I.D. TO 6.45-6.55  
x 15.00-17.00 DEEP.

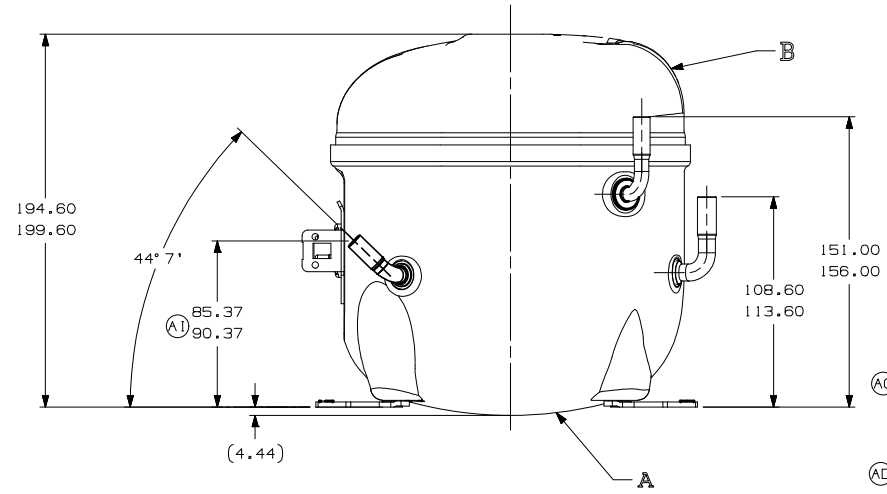
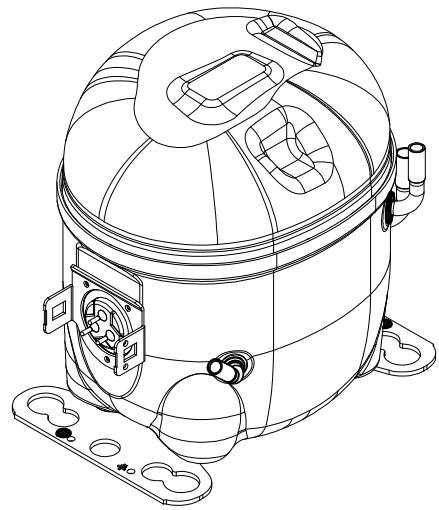

- NOTES:
- 1- IF SPECIFIED IN BM. ASSEMBLE PARTS AS SHOWN.
  - 2- SEE SPEC. "A-B" & A-C FOR PROCESS.
  - 3- THERE CAN BE NO CREASES IN THE TUBES. (CREASES ARE SIGNS OR MARKS THAT ARE IN SOMETHING THAT BENDS)
  - 4- AFTER THE FOLDS IN THE TUBES, CANNOT BE ACCELERATED TO AREA EXCEEDING 30%.
  - 5- TUBES OF SUCTION, DISCHARGE AND PROCESS MUST BE FREE OF INK ON 15.8mm (5/8") FROM TOP OF THE TUBES AS SPEC. T.P.Co. A-B4.
  - 6- FOR SUPPLIER ENVIRONMENTAL REGULATORY REQUIREMENTS, SEE TECUMSEH GLOBAL SPEC. 08.

THIRD ANGLE PROJECTION

UNITS: mm

DRAWING SIZE: A2

LEGEND:

- ★ = CATEGORY I
- ▲ = CATEGORY II
- = CATEGORY III
- = CATEGORY IV



NAME			PARTY NO.	
SALES COMPRESSOR			DCAE196	
DWN.	CK.	APR.	SCALE	PAGE
J. BARBANO	ANDRE MARTINEZ	WALTER CORREA	1:2	1/1
DATE	REF.	FAMILY	AE2	
09/06/11				

B5	ERA	91.60-96.60	EC102367	02-09-2002	RF
D4	ERA	86.60-91.60	EC90775	08-08-1998	RF
E5	ERA	72.10-77.10	EC70368	14-02-1996	RF
FB	ERA	14963573	EC59687	08-08-1998	RF
A1	A/2	ALTERADA MEDIDA (AREA TSENTA E ACRESC. NOTAS)	EC48189	03-03-1995	RF
AH	F/6	RETORNO DETALHE (AREA TSENTA DE PINTURA)	EC52840	01-01-14	RF
AG	F/7	ALTERADO TUBO D	EC44035	07/11/11	J.B / A.M
AF	F/7	ALTERADA MEDIDA (AREA TSENTA)	EC41721	07/11/11	J.B / W.C
AE	F/7	ALTERADA MEDIDA (AREA TSENTA)	EC29630	02/08/11	J.B / A.M
AD	A/2	ADICIONADO NOTA	EC172	07/11/11	J.B / W.C
AC	A/2	REVISADA NOTAS 3 E 4	EC1121	07/11/11	J.B / W.C
AB	A/1	ALTERADO NOME ERA: BROAD	EC1121	07/11/11	J.B / W.C
AA		LIBERACAO			
LT	LC	CHANGE	DATE		

THIS DRAWING OR PRINT (1) IS THE PROPERTY OF TECUMSEH DO BRASIL LTDA. AND CONTAINS PROPRIETARY AND CONFIDENTIAL INFORMATION. IT IS TO BE KEPT IN STRICTLY CONFIDENTIAL AND NOT TO BE REPRODUCED OR DISCLOSED TO ANY OTHER PARTY WITHOUT THE WRITTEN CONSENT OF TECUMSEH DO BRASIL. IF YOU ARE NOT AN EMPLOYEE OF TECUMSEH DO BRASIL AND NOT OTHERWISE (1)1) YOU SHALL NOT BE COPIED OR TO ANY EXTENT WITH- OUT THE WRITTEN CONSENT OF TECUMSEH DO BRASIL. IF YOU ARE AN EMPLOYEE OF TECUMSEH DO BRASIL AND NOT OTHERWISE (1)1) YOU SHALL BE HELD RESPONSIBLE FOR ANY UNAUTHORIZED DISCLOSURE OF THIS INFORMATION. IF YOU ARE AN EMPLOYEE OF TECUMSEH DO BRASIL AND NOT OTHERWISE (1)1) YOU SHALL BE HELD RESPONSIBLE FOR ANY UNAUTHORIZED DISCLOSURE OF THIS INFORMATION. IF YOU ARE AN EMPLOYEE OF TECUMSEH DO BRASIL AND NOT OTHERWISE (1)1) YOU SHALL BE HELD RESPONSIBLE FOR ANY UNAUTHORIZED DISCLOSURE OF THIS INFORMATION.