

ITEM	PART NUMBER
A	320-10156
B	14963286
C	14947663
D	580-10244
E	14963572

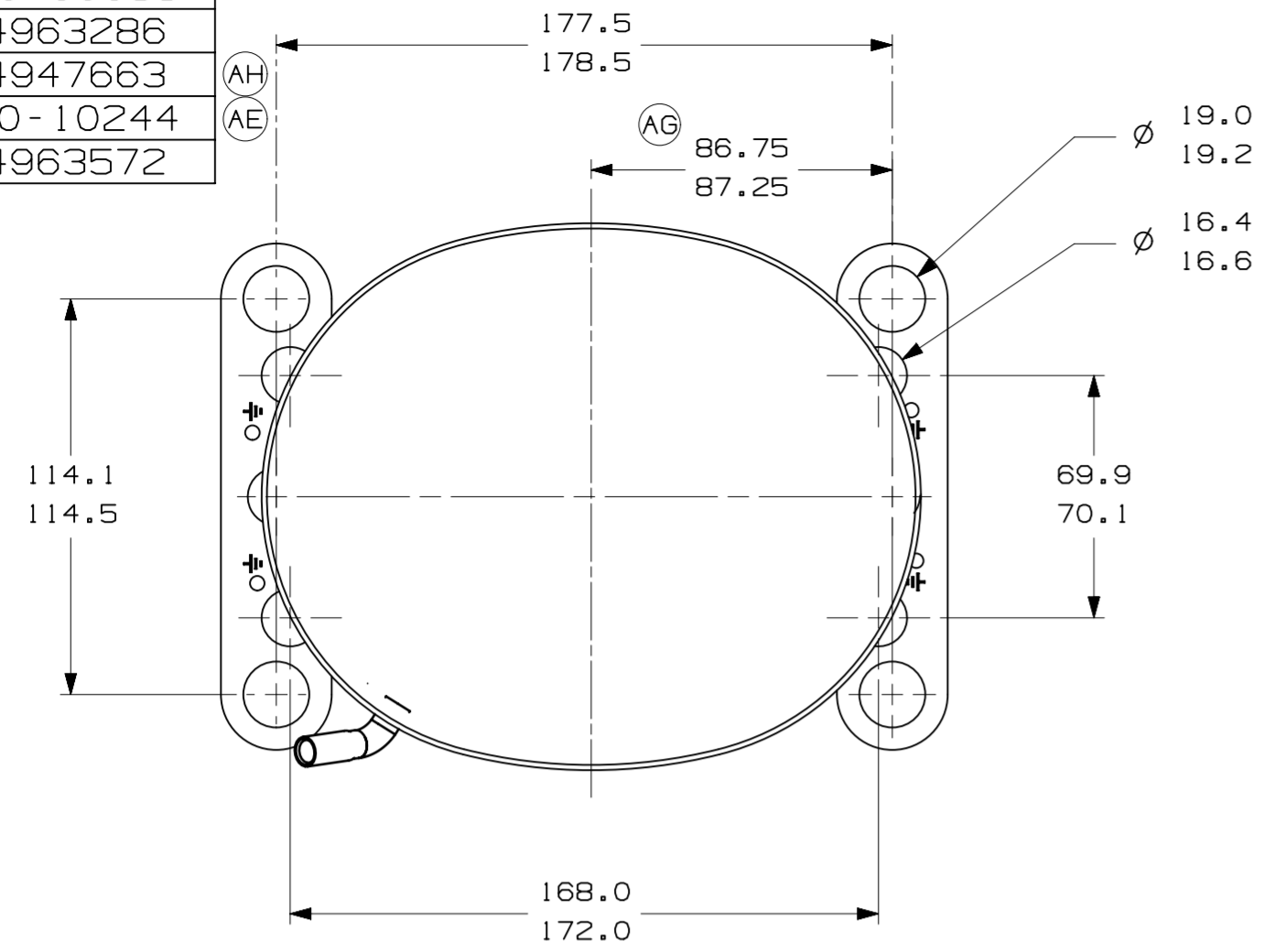

- AUXILIARY VIEW -
FASTENING DIMENSIONS

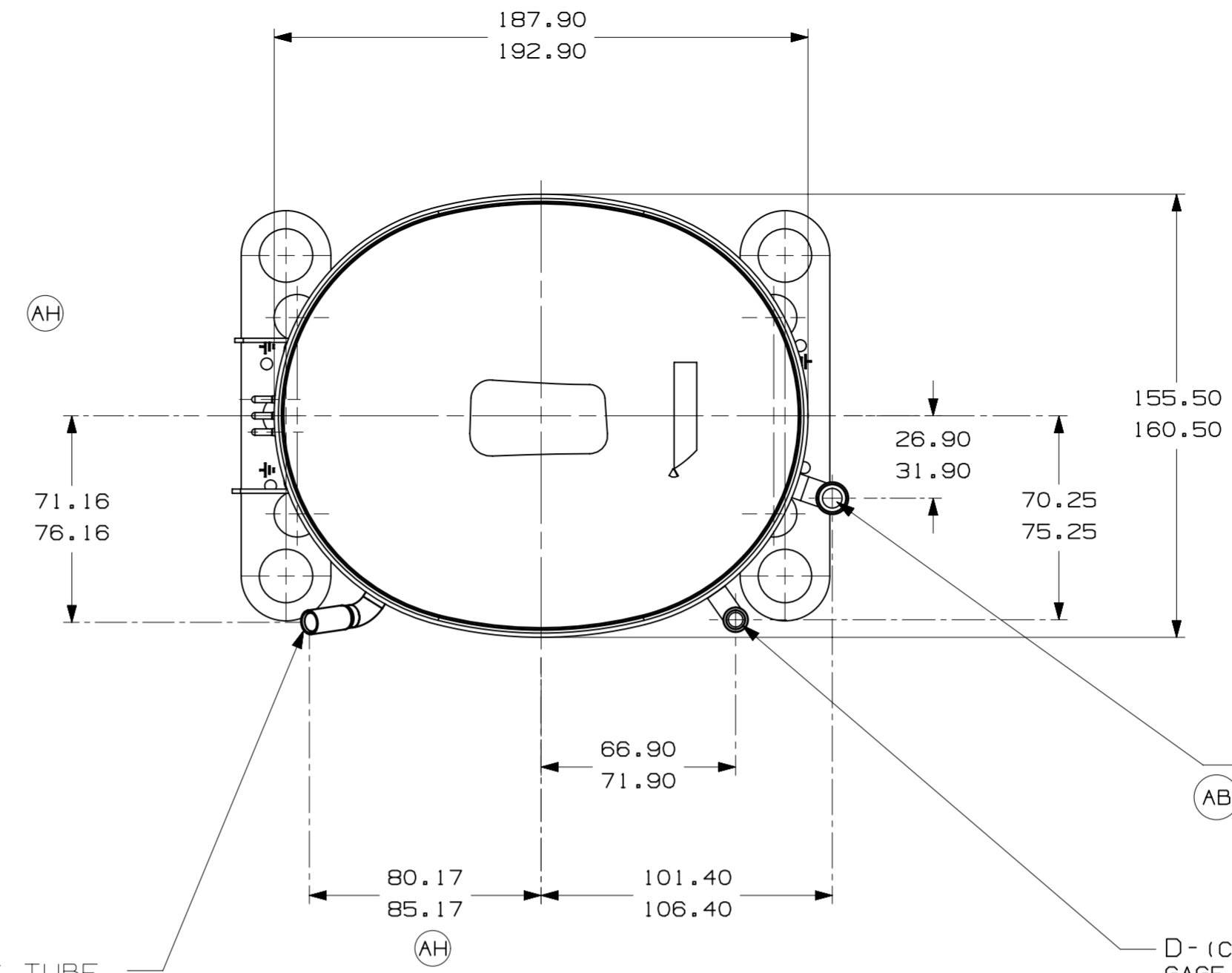

E- (COPPER) SUCTION TUBE
GAGE I.D. TO 9.6-9.7
× 15.00-17.00 DEEP.

D- (COPPER) DISCHARGE TUBE
GAGE I.D. TO 6.45-6.55
× 13.00-15.00 DEEP.

C- (COPPER) PROCESS TUBE
GAGE I.D. TO 6.45-6.55
× 15.00-17.00 DEEP.

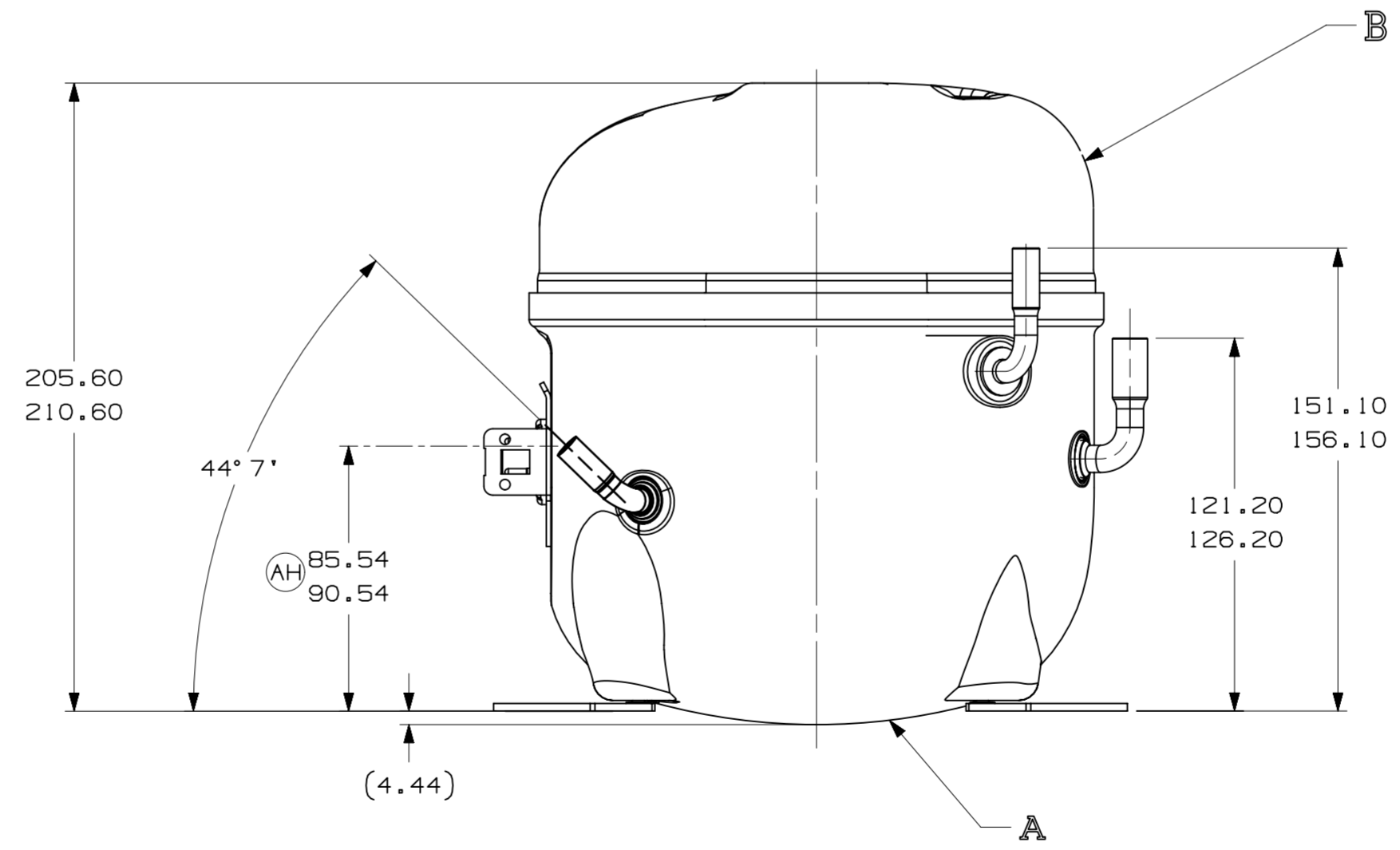
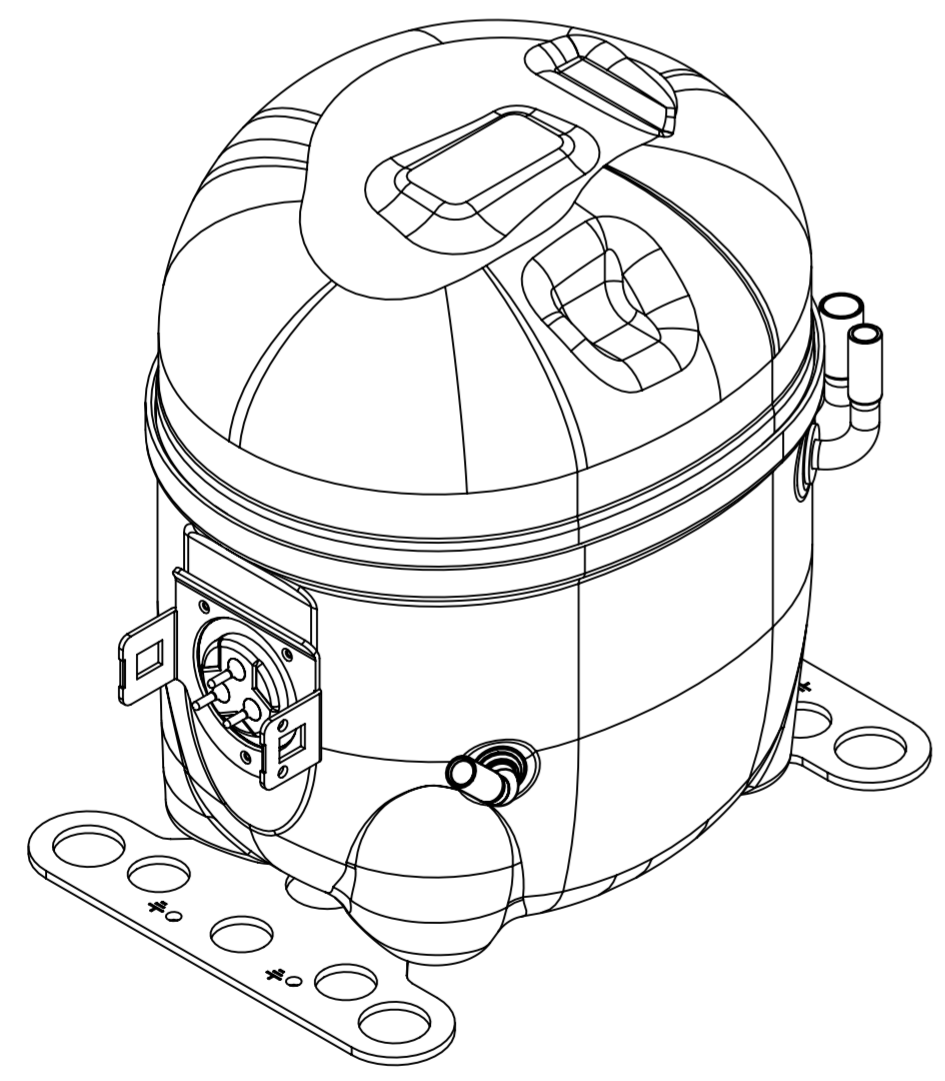

- NOTES:
- IF SPECIFIED IN BM. ASSEMBLE PARTS AS SHOWN.
 - SEE SPEC. "A-B" & A-C FOR PROCESS.
 - THERE CAN BE NO CREASES IN THE TUBES. (CREASES ARE SIGNS OR MARKS THAT ARE IN SOMETHING THAT BENDS)
 - AFTER THE FOLDS IN THE TUBES, CANNOT BE ACCELERATED TO AREA EXCEEDING 30%.
 - TUBES OF SUCTION, DISCHARGE AND PROCESS MUST BE FREE OF INK ON 15.8mm (5/8") FROM TOP OF THE TUBES AS SPEC. T.P.Co. A-B4.
 - FOR SUPPLIER ENVIRONMENTAL REGULATORY REQUIREMENTS, SEE TECUMSEH GLOBAL SPEC. 08.

DATE	CHANGE	DESCRIPTION
02-05-22	GM. RG.	EC102387
02-05-22	GM. RG.	ERA 91.60-96.60
02-05-22	GM. RG.	ERA 86.60-91.60
02-05-22	GM. RG.	ERA 72.10-77.10
02-05-22	GM. RG.	ERA 14963573
02-05-22	GM. RG.	ALTERA MEDIDA F77 E ACRES. NOTA 6
02-05-22	GM. RG.	ALTERA MEDIDA F77 E ACRES. NOTA 6
02-05-22	GM. RG.	RETIRADO DETALHE (AREA ISENTA DE PINTURA)
02-05-22	GM. RG.	ALTERADO TUBO D ERA: 14963519
02-05-22	GM. RG.	ADDED NOTE
02-05-22	GM. RG.	REVISADA NOTAS 3 E 4
02-05-22	GM. RG.	ACRESCENTADA NOTAS 3 E 4
02-05-22	GM. RG.	CORRIGIDO Ø INT. TUBO SUCCAO ERA: Ø 8.00-8.10
02-05-22	GM. RG.	LIBERACAO

THIRD ANGLE PROJECTION

UNITS: mm

DRAWING SIZE: A2

0. A SYMBOLS AS PROCEDURE 2.01.031 TECUMSEH OF BRAZIL

NAME: SALES COMPRESSOR

PART NO.: DCAE199

SCALE: 1:2

PAGE: 1/1

DATE: 22/09/11

REF.

FAMILY: AE2