

ITEM	PART NUMBER
A	14963286
B	HA-10576
C	14963573
D	580-10244
E	14963572

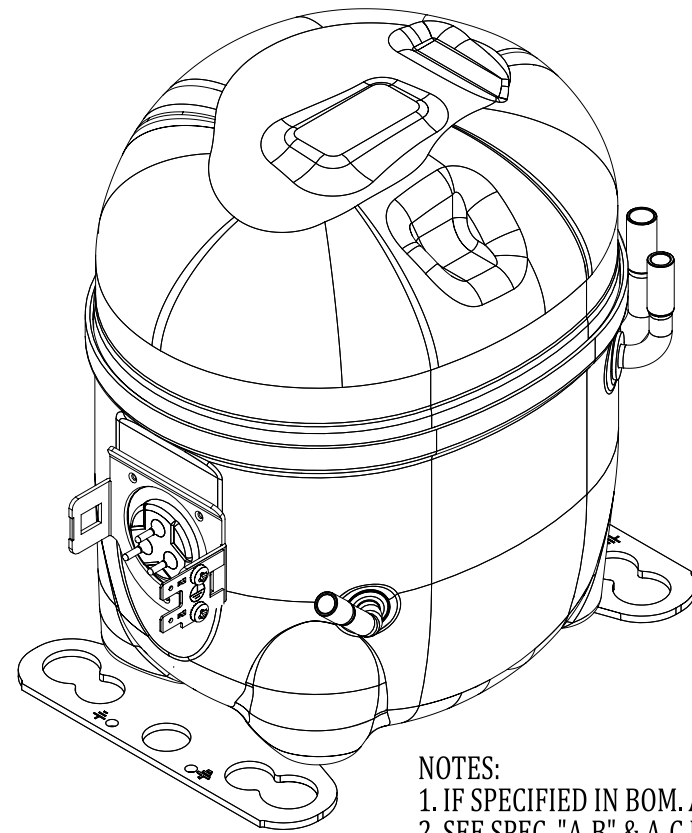

**FOR DEVELOPMENT**

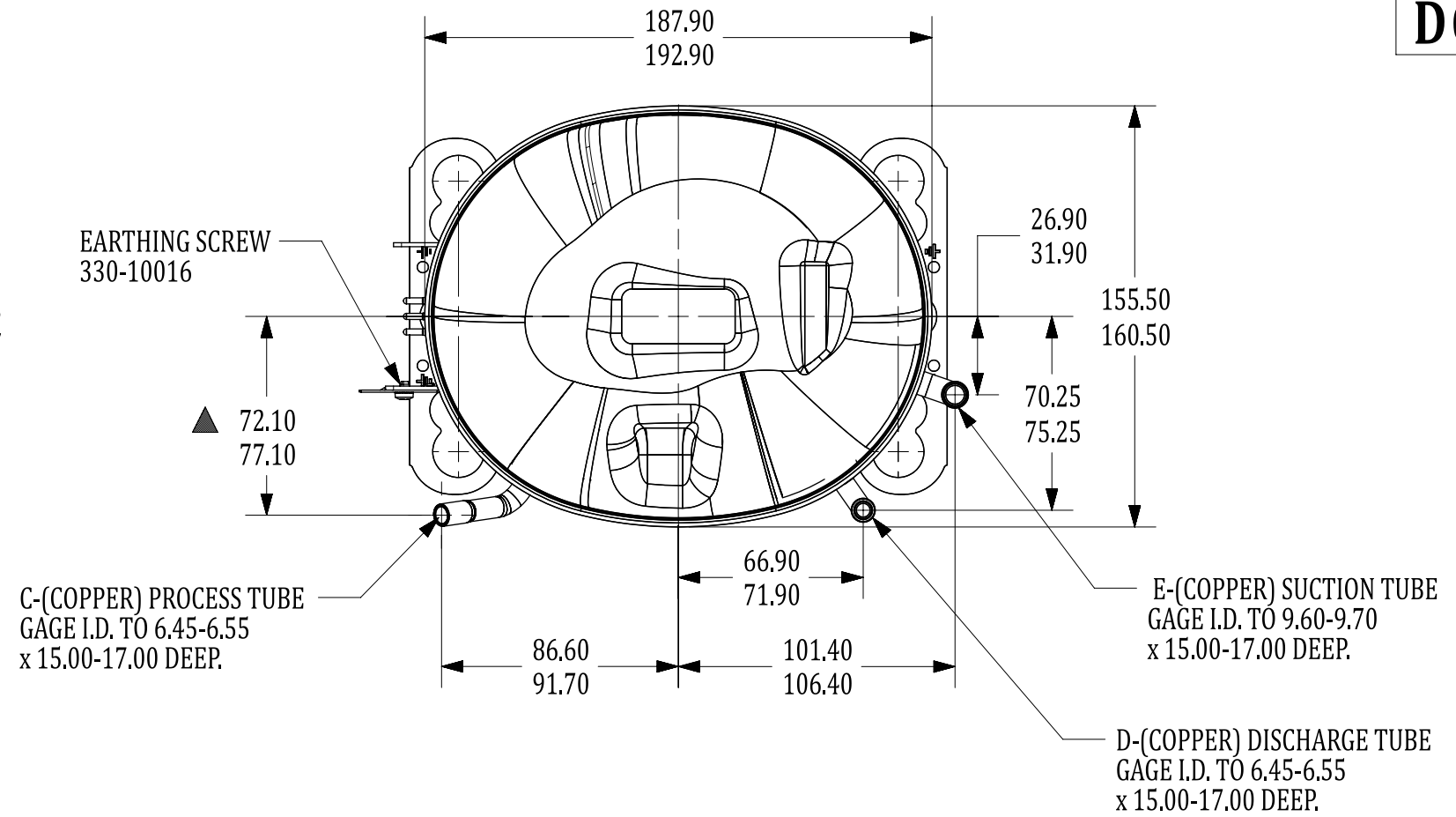
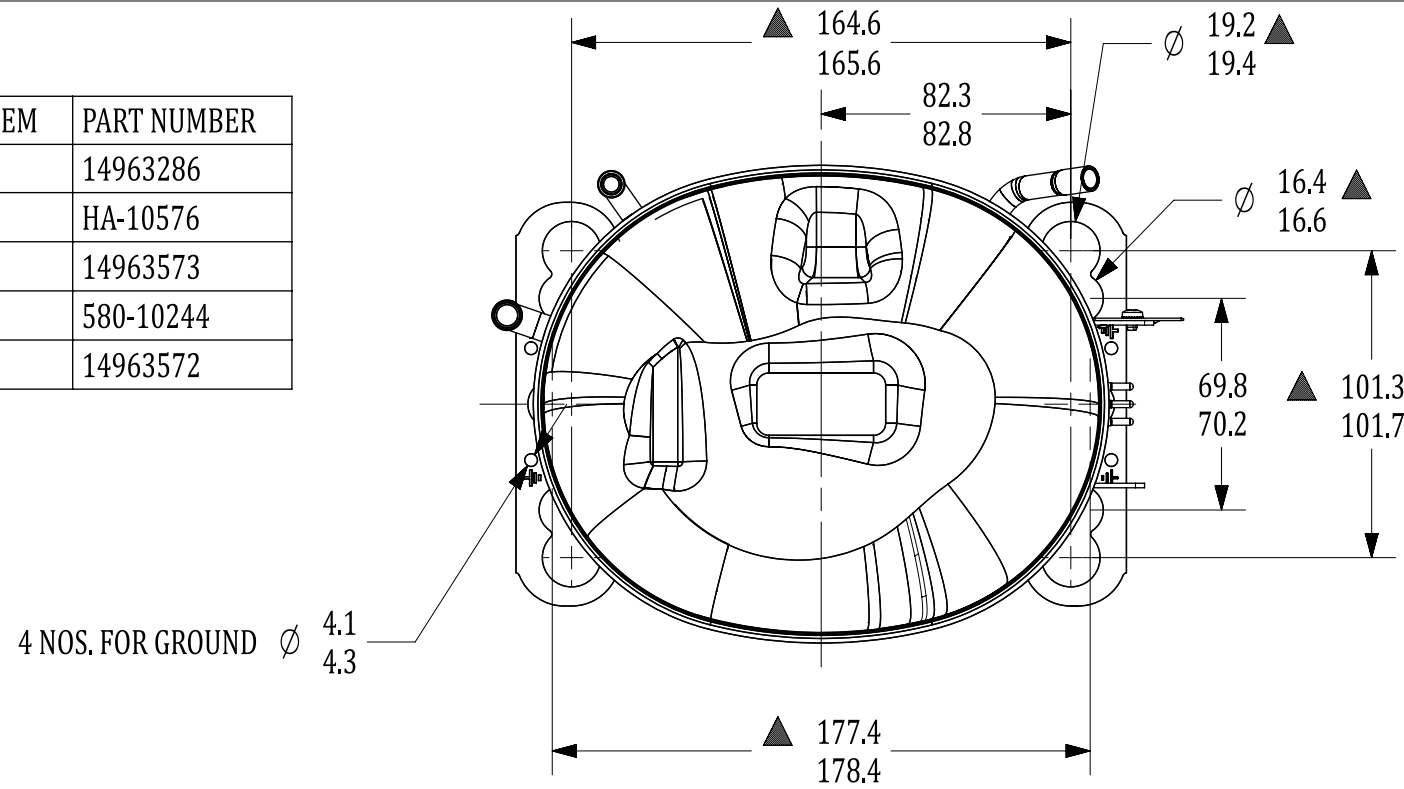
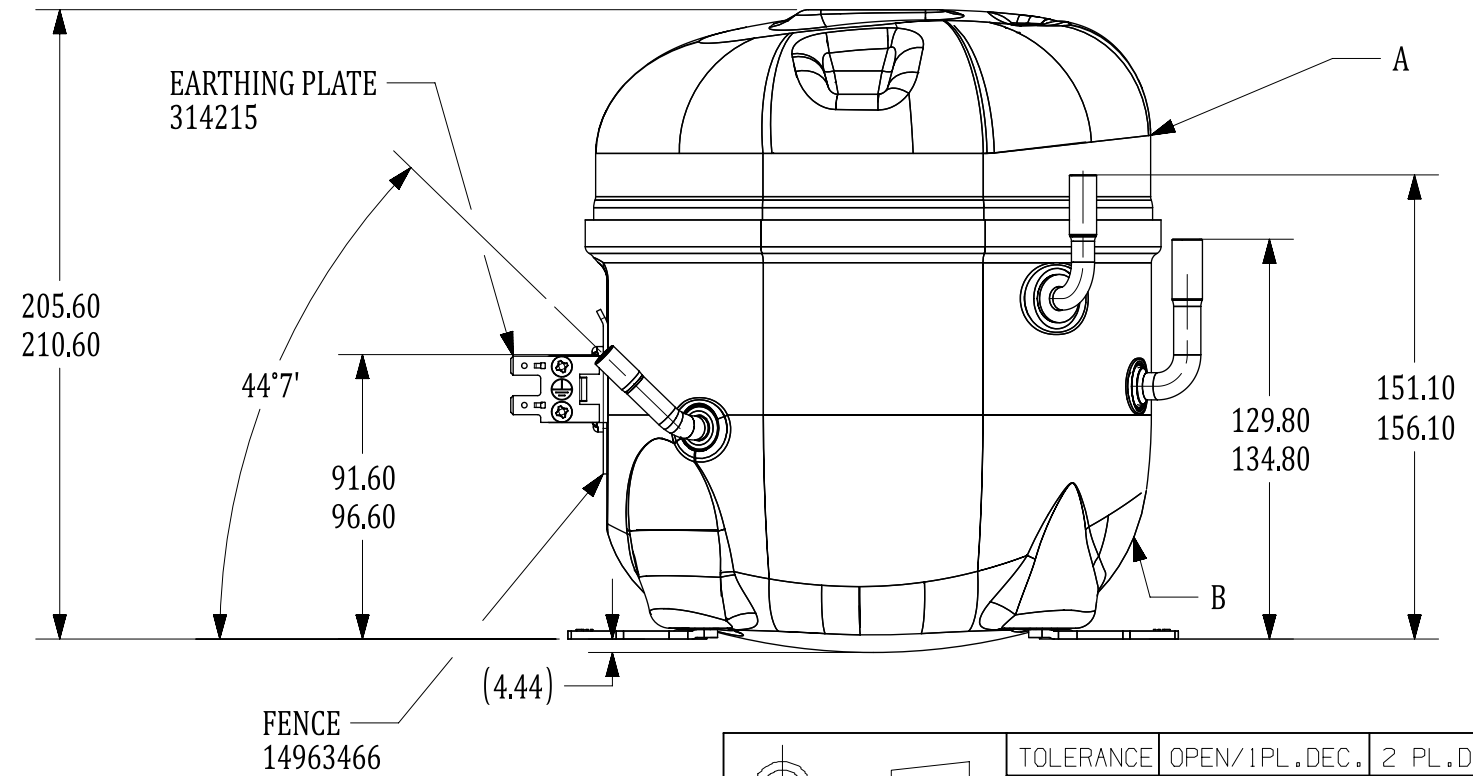

- NOTES:
- IF SPECIFIED IN BOM. ASSEMBLY PARTS AS SHOWN.
  - SEE SPEC. "A-B" & A-C FOR PROCESS.
  - THERE CAN BE NO CREASES IN THE TUBES, (CREASES ARE SIGNS OF MARKS THAT ARE IN SOMETHING THAT BENDS)
  - AFTER THE FOLDS IN THE TUBES, CANNOT BE ACCELERATED TO AREA EXCEEDING 30%.
  - THE SERIAL LABEL SHOULD BE ON THE SIDE OPPOSITE THAT SHOWN ABOVE, ONLY FOR MODEL AE1048BR.
  - TUBES OF SUCTION, DISCHARGE AND PROCESS MUST BE FREE OF PAINT ON 15.8 mm FROM TOP OF THE TUBES AS SPEC. TP.CO.-A-B4

**Q.A. SYMBOLS**

- ★ = CATEGORY I
- ▲ = CATEGORY II
- = CATEGORY III
- = CATEGORY IV

XX	LT	LC	CHANGE	DATE
---	---	---	ECXXXXX	---

THIS DRAWING OR PRINT (1) IS THE PROPERTY OF TECUMSEH PRODUCTS COMPANY (TECUMSEH) AND CONTAINS PROPRIETARY AND CONFIDENTIAL INFORMATION. ANY REPRODUCTION, COPIING, OR DISSEMINATION OF THIS INFORMATION WITHOUT THE WRITTEN CONSENT OF TECUMSEH IS STRICTLY PROHIBITED. THE RECIPIENT OF THIS INFORMATION SHALL BE RESPONSIBLE FOR THE PROTECTION OF THIS INFORMATION AND SHALL RETURN IT TO TECUMSEH UPON THE RECIPIENT'S REQUEST. THIS DRAWING IS MADE TO SCALE. THIS DRAWING ALL FERROUS MATERIALS MUST NOT BE MAGNETIZED AS RECEIVED OR AT COMPRESSOR ASSEMBLY.

TOLERANCE	OPEN/1PL.DEC.	2 PL.DEC.	3 PL.DEC.
LINEAR			
ANGULAR			

NAME: **AE2 SALES COMPRESSOR**

THIS PRINT SUPERSEDES ALL PRINTS PRIOR TO

ROHAN 24APR24	ON FILE	ON FILE	SCALE 1:4 & NOTED
------------------	---------	---------	-------------------------

DRAWING NO. **DCAE207**

SHEET 1/1

TECUMSEH PRODUCTS INDIA LTD.  
BALLABGARH, INDIA