

NOTES

- 1- Voir specification pour plans DC SP0011 .
According to TE SPEC SP0011
- 2- Les cotes sont donnees a titre d'indication. Se reporter aux plans des pieces.
Dimensions are given as an indication. Refer to the planes of the parts.
- 3- Etiquettes : references suivant nomenclatures et specification SP2004.
Labels : References according to BOM & TE SPEC SP2004.
- 4- Plugs non representes sur vues filaires.
Plugs not represented except on shaded view.

Note :
Ces vues s'appliquent a la personnalisation des compresseurs faite aux US :
Assembler les composants comme montres, suivant contenu des nomenclatures.
These views are applicable to compressor customization made in US :
If specified on B.O.M: assemble these parts as shown

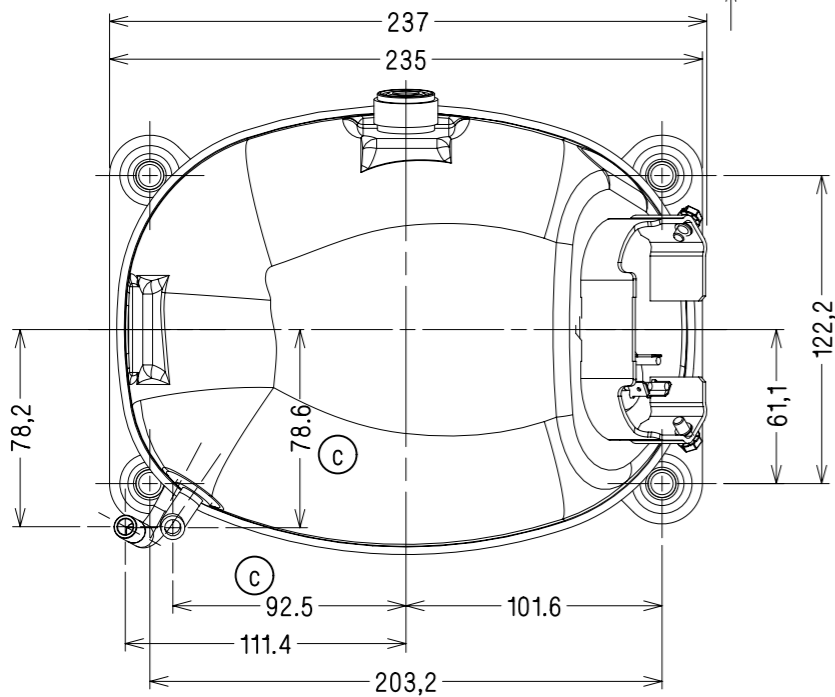
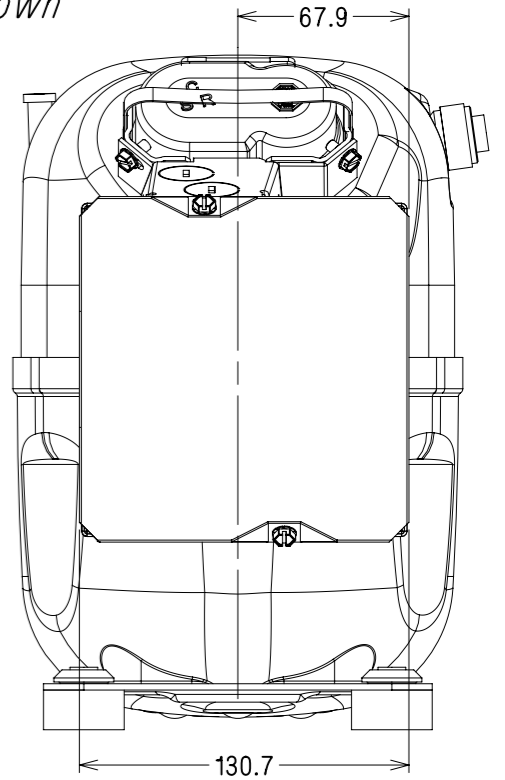
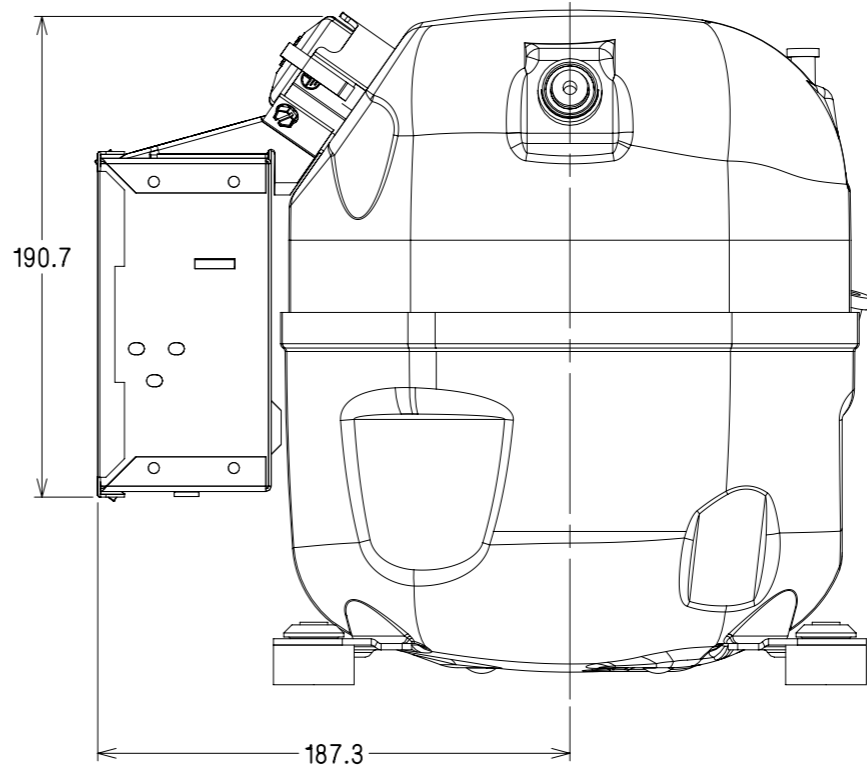
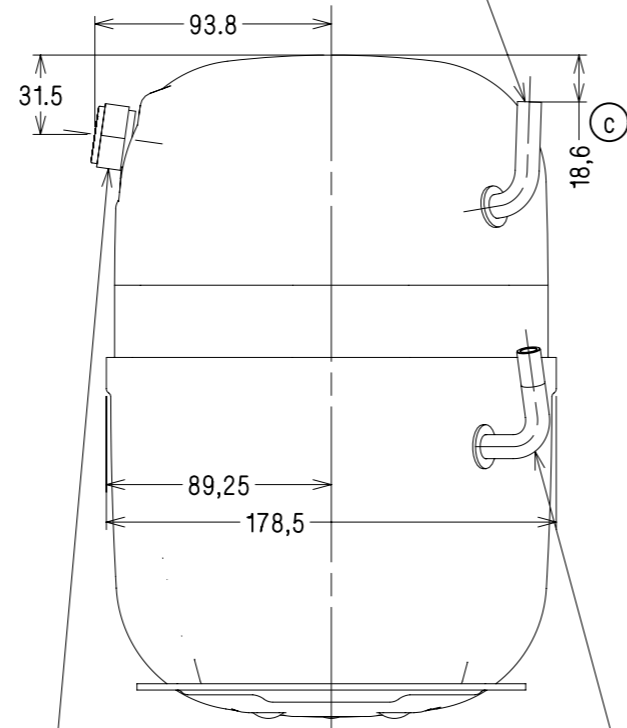
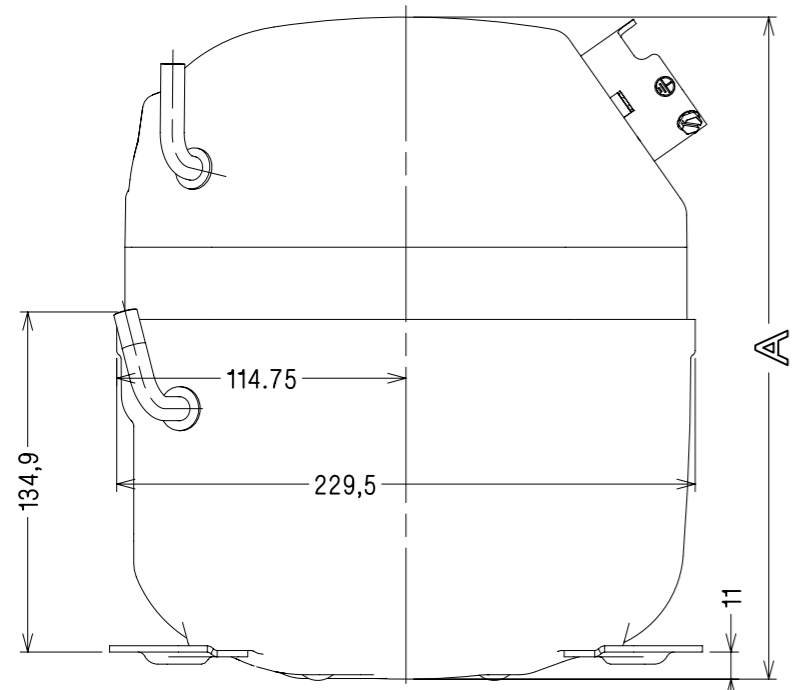

EMBOUT ASPIRATION
VOIR TABLEAU
SUCTION SPUD
SEE TABLE

TUBE REFOULEMENT
VOIR TABLEAU
DISCHARGE TUBE
SEE TABLE

Modele represente : DCAJ740
Echelle : 1/4
Represented model : DCAJ740
Scale : 1/4

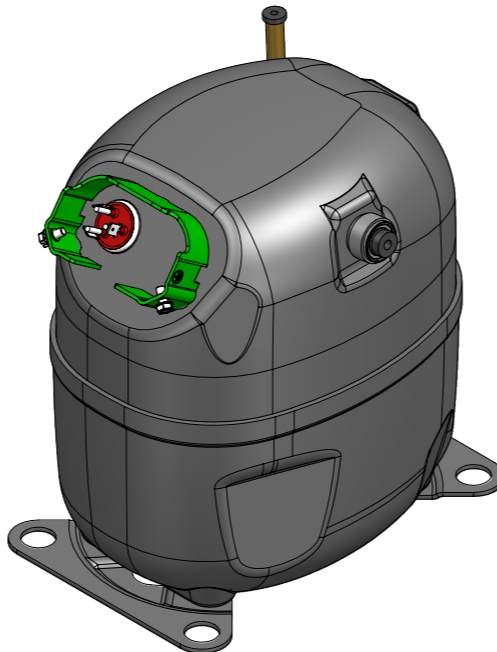

Plan DC	A	Tube Charge Ø int. Process tube I.D.	Aspiration Ø int. Suction I.D.	Tube Refoulement Ø int. Discharge tube I.D.
DCAJ740	263			Tube cuivre Ø 6,45 mini Copper tube Sur longueur On length 12 Bouchon Plug 364003
DCAJ743	275	Tube cuivre Ø 6,45 mini Copper tube Sur longueur On length 12 Bouchon Plug 364003	Embout vanne 1" Spud Bouchon 364005 Plug	Tube cuivre Ø 8 mini Copper tube Sur longueur On length 19 Bouchon Plug 364004
DCAJ746	275			Tube cuivre Ø 9,6 mini Copper tube Sur longueur On length 19 Bouchon Plug 364005

**COTES CRITIQUES
Q.A. SYMBOLS**

★	CATEGORIE 1	CATEGORY 1
▲	CATEGORIE 2	CATEGORY 2
■	CATEGORIE 3	CATEGORY 3
□	CATEGORIE 4	CATEGORY 4

CATEGORIES DEFINIES PAR SP7121
IN ACCORDANCE WITH SPA7121

ATTENTION DOCUMENT STRICTEMENT CONFIDENTIEL ET PRIVE
Ce document est la propriete exclusive de TECUMSEH EUROPE SA et renferme des informations ayant un caractere prive et confidentiel.
Ce document est remis sous la condition formelle que son contenu ne sera pas divulgue a un tiers, ni reproduit, ni adapte ou publie sans le consentement exprès de TECUMSEH EUROPE et qu'il pourra être utilisé qu'après l'autorisation écrite de ladite société. Sur simple demande de TECUMSEH EUROPE le present document devra lui être restitué intégralement.
ATTENTION STRICTLY CONFIDENTIAL AND PRIVATE DOCUMENT
This document is the exclusive property of TECUMSEH EUROPE SA and contains information of a private and confidential nature.
This document is given under the formal condition that its content will be disclosed to a third party, neither reproduced, nor adapted or published without the express consent of TECUMSEH EUROPE and that it can only be used after the express authorization of said company. Upon simple request from TECUMSEH EUROPE, this document must be returned in full.

A.M. File no.	Ind Rev	Rep. Mark	Modifications Change content	Date Date	Visa Sign	Verif Check
EC105337	d	-	Correction zone 4 a 3,5	30jun22	RP	PM
EC104556	c	-	MAJ tube de charge	23may22	RP	LE
EC97740	b	-	Mise a jour	14jan21	RP	BC
EC98517	a	-	Prelancement	11nov20	RP	BC

MATIERE: Conforme a la specification T.P.Co. Global 08 ▲
Material: Must comply with T.P.Co. Global Spec 08 ▲

TOLERANCES GENERALES GENERAL TOLERANCES	lineaire: ± 2,5 angulaire: ± 1°	
--	------------------------------------	--

ECH. Scale 1/3	ORIGINE Origin
	-

COMPRESSEUR AJ2 a SPUD Aspiration en zone 3.5 Spud version Suction in zone 3.5	TECUMSEH EUROPE S.A. 38090 VAULX-MILIEU	Indice Revision d
	DCAJ740 NO	

Ce plan est propriete exclusive de notre societe tous droits de reproduction et de diffusion reserves.
This drawing is the property of our society copyrights and publications reserved.

D

C

B

A