

PART NO.
DCAK035-3

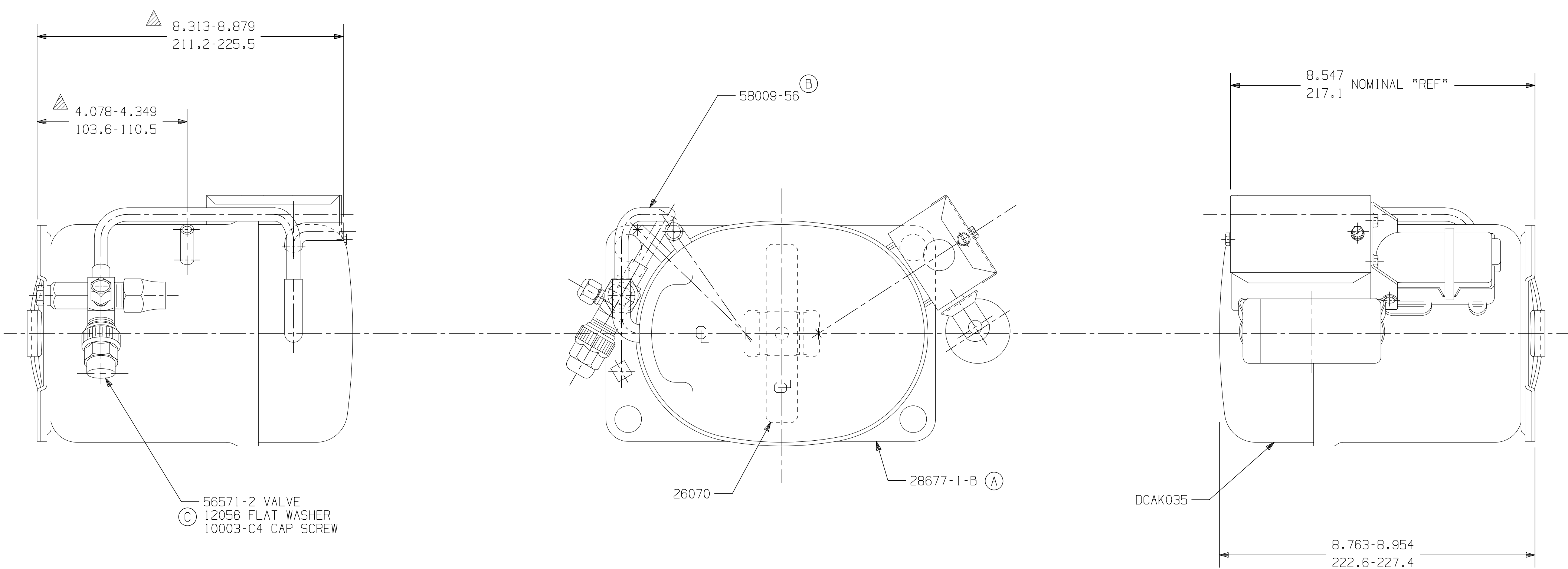

NOTE!
1. IF SPECIFIED ON BILL OF MATERIAL ASSEMBLE THESE PARTS AS SHOWN.
2. SEE COMPONENT DRAWINGS FOR DIMENSIONS NOT SHOWN.

DIMENSIONING = INCHES OR INCHES - (MILLIMETERS)
MILLIMETERS

Q.A. SYMBOLS

- ★ = CATEGORY I
- ▲ = CATEGORY III
- = CATEGORY IIII
- = CATEGORY IV

#237825-001 WAS 56571-2 WAS 56571-1 WAS 235820-028 56571-1 WAS 56571-1 WAS 56571-1 WAS		LUCAS 01OCT03		W.E.M. 3/10/98		SJS 12/4/96		DATE		DIS. CODE 34D		NAME SALES COMPRESSOR		THIS PRINT SUPERSEDES ALL PRINTS PRIOR TO	
#235820-040 WAS 58174		#235241 WAS 28677-1		#231943-2		DATE		DATE		DWN. N. CLARK 5-24-95		CK 12		MATERIAL —	
C 7C		B 4E		A 3C		REL		LT LC		DO NOT SCALE THIS DRAWING. ALL FERROUS MATERIALS MUST BE IMAGETIZED AS RECEIVED OR AT COMPRESSOR ASSEMBLY.		TECUMSEH PRODUCTS CO. TECUMSEH, MICHIGAN		PART NO. DCAK035-3	