

SCHEMATIC WIRING DIAGRAM - 3 PHASE INTERNAL OVERLOAD (LINE BREAK) CRANKCASE HEATER. REF. DWG. MD472-43

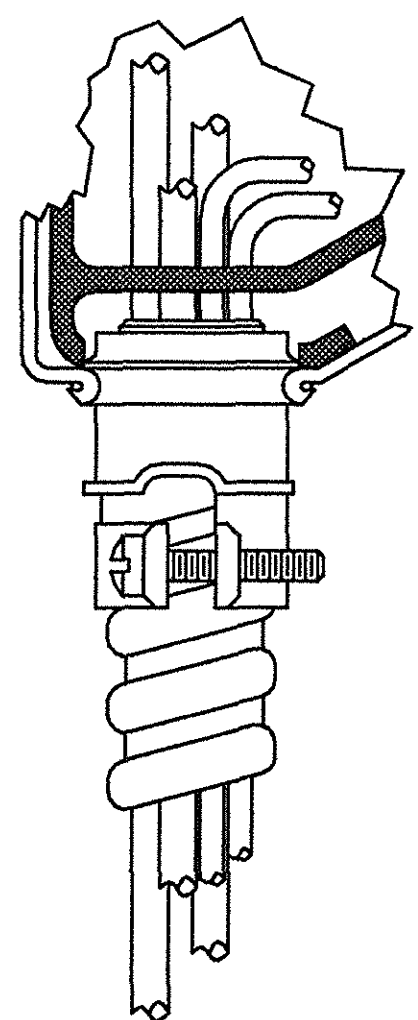

ALTERNATE IF CONDUIT IS USED.

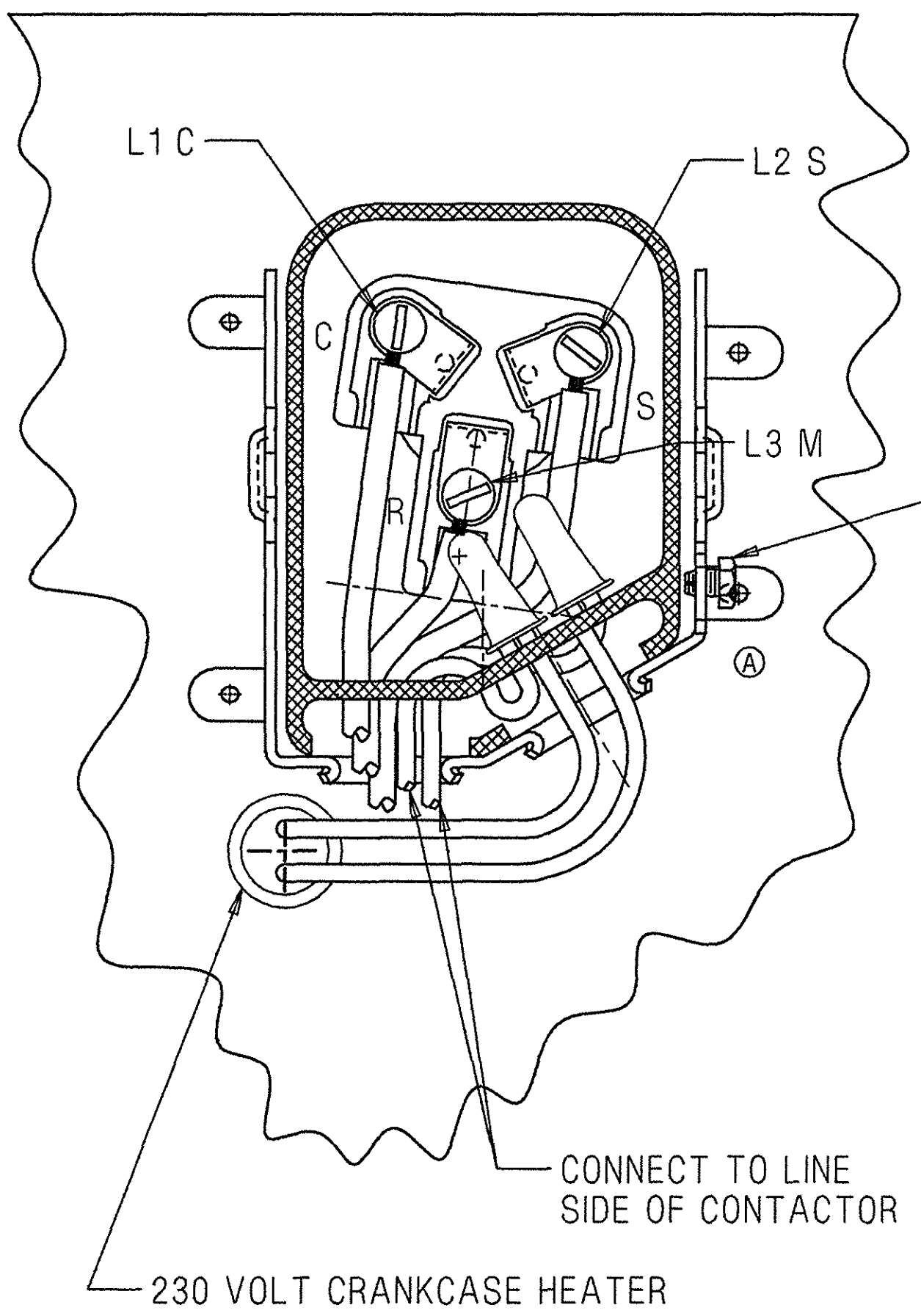

(B) COMPRESSOR UNIT GROUND (SCREW IS NOT PROVIDED BY T.P. CO.)

WARNING-WIRING DIAGRAM MUST BE FOLLOWED AS SHOWN, ANY MISWIRING CAN CAUSE SERIOUS ELECTRICAL HAZARD AND POTENTIAL DAMAGE OR RUPTURE OF COMPONENT ELECTRICAL PARTS.

AV-3 PHASE-INTERNAL OVERLOAD (LINE BREAK)-CRANKCASE HEATER.

Q.A. SYMBOLS

AV

#223682 ADDED SJS COMPRESSOR UNIT GROUND 4/9/97		#229431 REVISED TERMINAL GUARD T.M.G. 3/18/94		DATE	REL.#222456	CHANGE	DATE	DIS.CODE	3452	NAME	ELECTRICAL HOOK-UP	SCALE	1" = 1"	THIS PRINT SUPERSEDES ALL PRINTS PRIOR TO
TECUMSEH PRODUCTS CO. TECUMSEH, MICHIGAN											PART NO.		DEAV-4	
INTERNAL USE ONLY UGIDISK51(SHERMAN)AV-DEAV041CB-C.PRT														