

USE ONLY PROCESS CONNECTOR - COPPER  
 O.D. 7.89-7.99 - WALL 0.90-1.10  
 END I.D. 6.45-6.55 X 15.0-17.0 DEEP.  
 PLUG. 40

DISCHARGE CONNECTOR - COPPER  
 O.D. 7.00-7.10 - WALL 0.90-1.10  
 END I.D. 4.92-5.02 X 15.0-17.0 DEEP.  
 PLUG. 1

USE ONLY SUCTION CONNECTOR - COPPER  
 O.D. 7.89-7.99 - WALL 0.90-1.10  
 END I.D. 6.45-6.55 X 15.0-17.0 DEEP.  
 PLUG. 40

NOTES  
 1- IF SPECIFIED IN BM. ASSEMBLE PARTS AS SHOWN.  
 2- SEE SPEC. "A-B" & A-C FOR PROCESS.  
 3- FOR SUPPLIER ENVIRONMENTAL REGULATORY REQUIREMENTS, SEE T. P. CO. GLOBAL SPEC. 08  
 4- TUBES OF SUCTION, DISCHARGE AND PROCESS MUST BE FREE OF INK ON 15.8mm (5/8") FROM TOP OF THE TUBES AS SPEC. T.P.Co. AB-4.

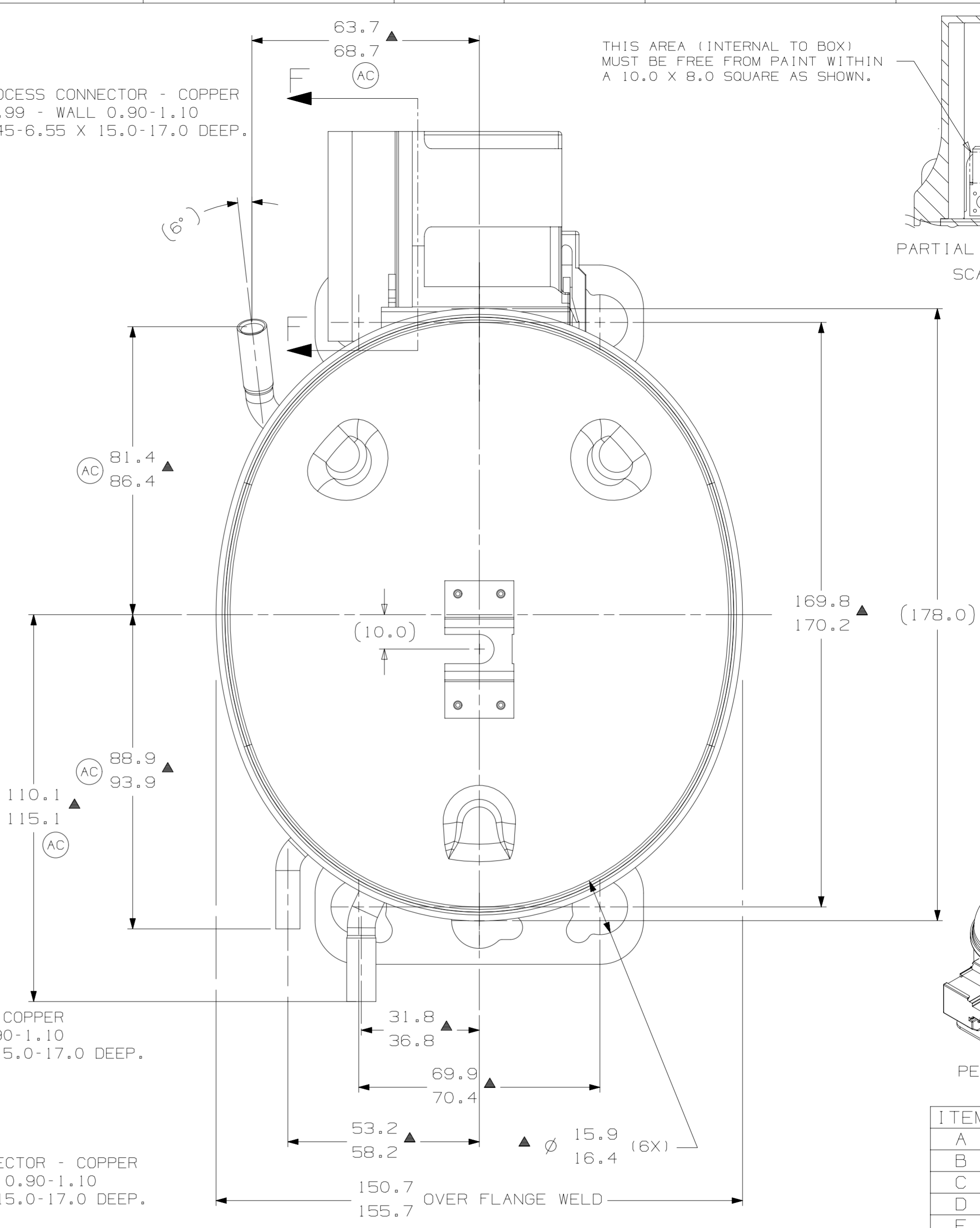

THIS AREA (INTERNAL TO BOX) MUST BE FREE FROM PAINT WITHIN A 10.0 X 8.0 SQUARE AS SHOWN.

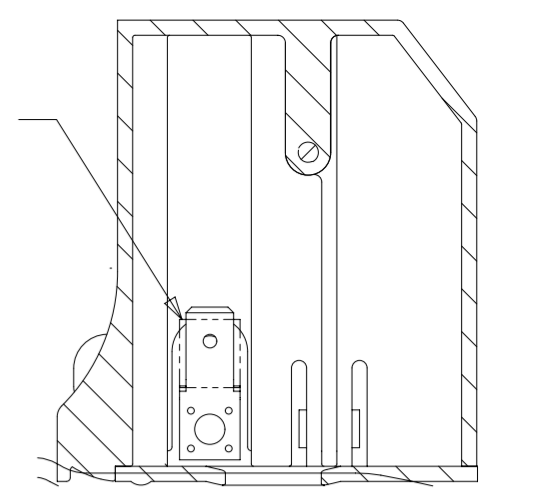

PARTIAL SECTION F-F  
 SCALE 1:1

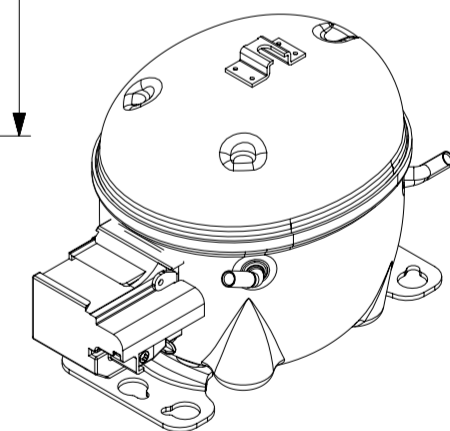

PERSPECTIVE VIEW  
 SCALE 1:4

ITEM	PART NUMBER
A	320-10143
B	320-10138
C	14947662
D	14947663
E	14947663

EC98010 06-07-21 CIAS. CS.	EC66313 25-08-15 AMP. VSS	EC56108 03-01-14 AMP. WF	DATE	THIS DRAWING OR PRINT (1) IS THE PROPERTY OF TECUMSEH DO BRASIL LTDA. AND CONTAINS PROPRIETARY AND CONFIDENTIAL INFORMATION BELONGING TO TECUMSEH DO BRASIL. IT IS TO BE USED ONLY FOR THE SPECIFIC CONDITION THAT IT APPEARS ON AND THE INFORMATION CONTAINED THEREIN OR DISCLOSED OR MADE AVAILABLE TO OTHERS WITHOUT THE EXPRESS AND SPECIFIC WRITTEN CONSENT OF TECUMSEH DO BRASIL AND IS NOT TO BE REPRODUCED, COPIED, EITHER WHOLLY OR IN PART, OR TRANSMITTED IN ANY MANNER WITHOUT THE EXPRESS AND SPECIFIC WRITTEN CONSENT AND IT SHALL BE RETURNED BY THE RECIPIENT LATTER'S REQUEST PROMPTLY AFTER SUCH REQUEST IS MADE.
ATUALIZADA 320-10138	ALTERADO PLUG ERA: PLUG 2	LIBERACAO	CHANGE	THIRD ANGLE PROJECTION
4F 5C 5E 5F 5B	F5 A5	AA	LT LC	UNITS: mm
AC	AB	AA	AA	DRAWING SIZE: A2
				0. A. SYMBOLS AS PROCEDURE 2.01.031 TECUMSEH OF BRAZIL
				★ = CATEGORY I
				▲ = CATEGORY II
				■ = CATEGORY III
				□ = CATEGORY IV

SALES COMPRESSOR

NAME: SALES COMPRESSOR

DATE: 17-12-13

REF.

PART NO. DCTA077

SCALE: 1:1

PAGE: 1/1

FAMILY: TA